

# TM 11-5820-295-10

DEPARTMENT OF THE ARMY TECHNICAL MANUAL

---

OPERATOR'S MANUAL  
RADIO SET AN/GRC-19



*HEADQUARTERS, DEPARTMENT OF THE ARMY*

*3 JUNE 1960*

# CONDENSED SIMPLEX VOICE OPERATING INSTRUCTIONS FOR RADIO SET AN/GRC-19

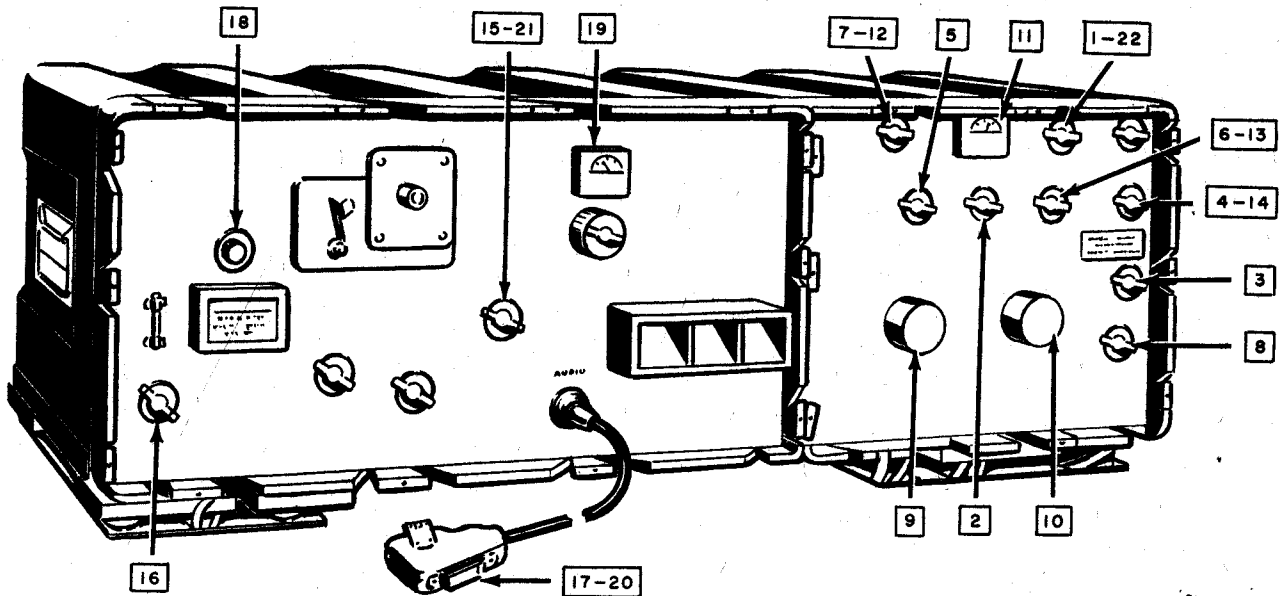

## OPERATING PROCEDURE FOR RECEIVER, RADIO R-392/URR

1. Set the function switch to NORMAL.
2. Set the AGC switch to ON.
3. Set the BAND WIDTH switch to 8.
4. Set the AF GAIN control to midposition.
5. Set the BFO switch to OFF.
6. Set the RF GAIN SQUELCH THRESH control to maximum clockwise.
7. Set the ANT TRIM control to 0.
8. Set the DIAL LOCK control to maximum counterclockwise.

TM5820-295-10-26 ①

CONTINUED ON BACK COVER.

TECHNICAL MANUAL }  
 No. 11-5820-295-10 }

HEADQUARTERS,  
 DEPARTMENT OF THE ARMY  
 WASHINGTON 25, D. C., 3 June 1960

## RADIO SET AN/GRC-19

		Paragraph	Page
CHAPTER	1.	INTRODUCTION	
Section	I.	General .....	1, 2      5
		Scope .....	1      5
		Forms and records .....	2      5
	II.	Description and data	
		Purpose and use .....	3      5
		Technical characteristics .....	4      5
		Components of Radio Set AN/GRC-19 .....	5      6
		Nomenclature and common names .....	6      7
		Description of Radio Set AN/GRC-19 .....	7      7
		Description of Transmitter, Radio T-195(*)/GRC-19 .....	8      7
		Description of Receiver, Radio R-392/URR .....	9      8
		Description of minor components .....	10      9
		Additional equipment required .....	11      13
		System application .....	12      13
CHAPTER	2.	INSTALLATION	
		Unpacking .....	13      17
		Checking unpacked equipment .....	14      19
		Siting .....	15      19
		Shelter requirements .....	16      19
		Connections .....	17      20
CHAPTER	3.	OPERATING INSTRUCTIONS	
Section	I.	Operator's controls and indicators	
		Damage from improper settings .....	18      23
		Transmitter, Radio T-195(*)/GRC-19, controls and indicators .....	19      23
		Receiver, Radio R-392/URR, controls and indicators .....	20      24
		Operation under usual conditions	
		Types of operation .....	21      25
		Adjustments and presetting .....	22      26
		Precautions .....	23      27
		Preliminary starting procedure .....	24      27
		Equipment operation chart .....	25      27
		Simplex VOICE operation .....	26      28
		Simplex CW operation .....	27      29
		Simplex FSK operation .....	28      30
		Simplex VOICE/FSK operation .....	29      31
		Duplex operation .....	30      32

\*This manual supersedes so much of TM 11-274, 27 April 1954, including C1, 7 February 1957, C4, 17 May 1957, and TM 11-5820-295-20P/TO 31R2-2GRC19-21, October 1959, as is applicable to the operator of the equipment.

			Paragraph	Page
	II.	Relay operation .....	31	32
		Remote operation .....	32	33
		Recognition and identification of jamming .....	33	34
		Antijamming .....	34	34
		Stopping procedure .....	35	35
CHAPTER	4.	MAINTENANCE INSTRUCTIONS		
		Scope of operator's maintenance .....	36	37
		Preventive maintenance .....	37	37
		Visual inspection .....	38	37
CHAPTER	5.	AUXILIARY EQUIPMENT		
		Purpose of auxiliary equipment .....	39	39
		Remote operation .....	40	39
CHAPTER	6.	SHIPMENT AND LIMITED STORAGE AND DEMOLITION TO PREVENT ENEMY USE		
	Section I.	Shipment and limited storage		
		Disassembly of equipment .....	41	42
		Repackaging for shipment or limited storage .....	42	42
	II.	Demolition of materiel to prevent enemy use		
		Authority for demolition .....	43	42
		Methods of destruction .....	44	42
APPENDIX	I.	REFERENCES .....		
	II.	REPAIR PARTS AND SPECIAL TOOLS LIST .....		

**WARNING**

**DANGEROUS VOLTAGES**

are used in this radio set:

Transmitter, Radio T-195/GRC-19 . . . 1,000-volt dc and  
10,000-volt rf circuits.

**DON'T TAKE CHANCES!**

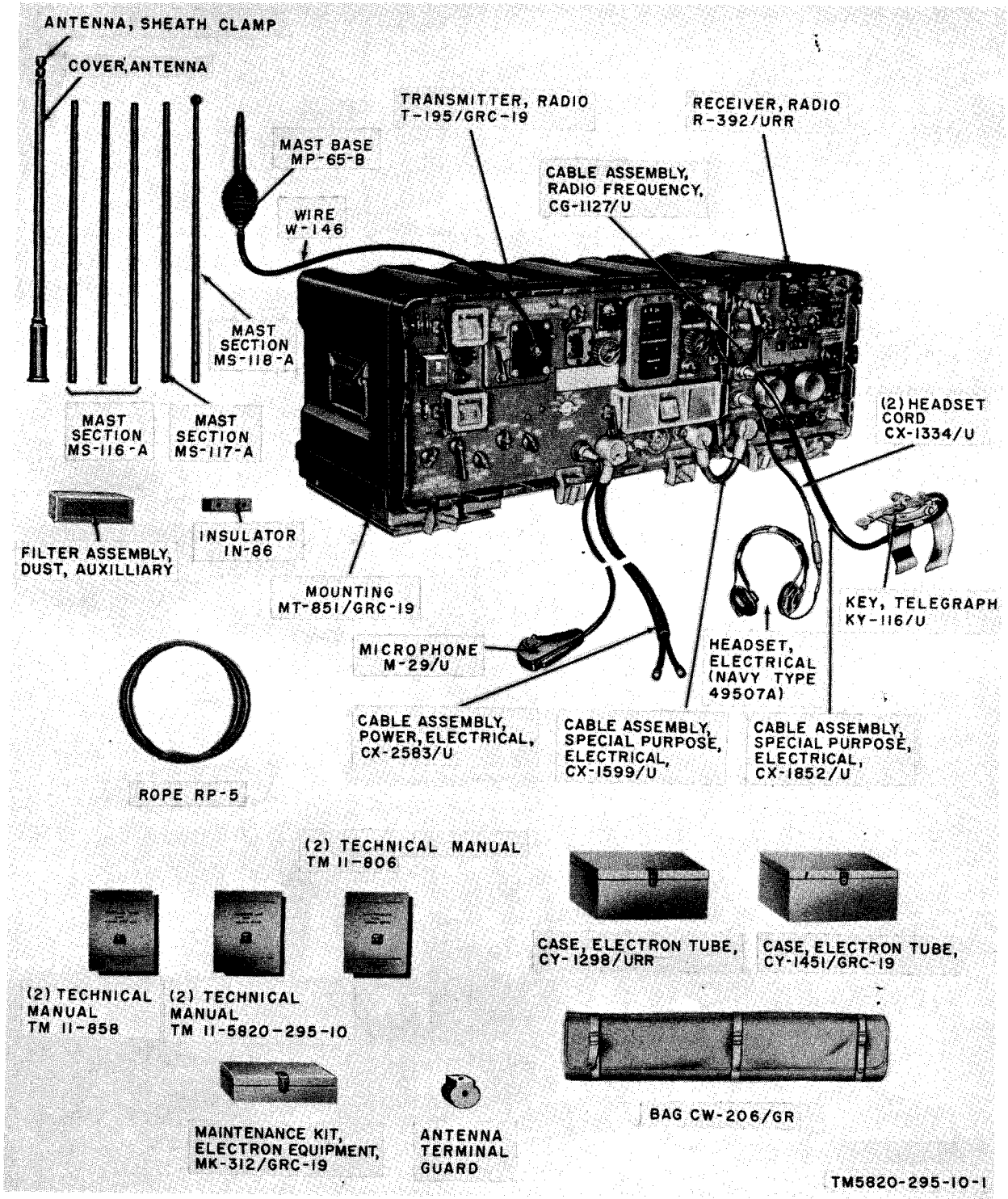

Figure 1. Radio Set AN/GRC-19.

# CHAPTER 1

## INTRODUCTION

### Section I. GENERAL

#### 1. Scope

a. This manual describes Radio Set AN/GRC-19 (fig. 1) and covers its installation, operation, and operator's maintenance. It includes operation under usual conditions, and cleaning and inspection of the equipment.

b. For detailed information on the receiver and transmitter of Radio Set AN/GRC-19, refer to TM 11-858 and TM 11-806.

c. Official nomenclature followed by (\*) is used to indicate all models of the equipment item covered in this manual. Thus Transmitter, Radio T-195(\*)/GRC-19 represents Transmitters, Radio T-195/GRC-19 and T-195A/GRC-19.

#### 2. Forms and Records

a. *Unsatisfactory Equipment Report.* Fill out and forward DD Form 787-1 (Electronic Failure Report—Signal Equipment) to the Commanding Officer, U. S. Army Signal Equipment Support Agency, Fort Monmouth, N. J., as prescribed in AR 700-38.

b. *Report of Damaged or Improper Shipment.* Fill out and forward DD Form 6 (Report of Damaged or Improper Shipment) as prescribed in AR 700-58.

c. *Preventive Maintenance Forms.* Prepare DA Form 11-238 (fig. 22 and 23) (Maintenance Check List for Signal Equipment (Sound Equipment, Radio, Direction Finding, Radar, Carrier, Radiosonde and Television)), in accordance with instructions on the form.

d. *Parts List Form.* Forward DA Form 2028 (Recommended Changes to DA Technical Manual Parts Lists or Supply Manuals 7, 8 and 9) direct to the Commanding Officer, U. S. Army Signal Equipment Support Agency, Fort Monmouth, N. J., with any comments on parts listings in appendix II.

e. *Comments on Manual.* Forward all other comments on this publication directly to the Commanding Officer, U. S. Army Signal Publications Agency, Fort Monmouth, N. J.

### Section II. DESCRIPTION AND DATA

#### 3. Purpose and Use

a. Radio Set AN/GRC-19, the major components of which are Transmitter, Radio T-195 (\*) /GRC-19 and Receiver, Radio R-392/URR, provides for transmission and reception of continuous-wave (cw) (A1), and voice signals (amplitude modulated) (A3), and also of frequency-shift-keyed radioteletype signals (fsk) (F1). Voice and fsk operation can be conducted simultaneously or independently. For fsk service, additional radioteletype equipment is required but not supplied as part of Radio Set AN/GRC-19. The transmitter operates in the range of 1.5 to 20 megacycles (mc) and the receiver within the range of 500 kilocycles (kc) to 32 mc. Remote control of the transmitter at distances up to 75 feet is possible when the transmitter is used in conjunction with auxiliary equipment (Transmitter Control C-822/GRC-19 and Cable Assembly, Special Purpose, Electrical CX-2585/U).

b. Radio Set AN/GRC-19 is designed primarily for vehicular installation; however, it can also be installed as a fixed-portable station. Radio Set AN/GRC-19 can be used for simplex, duplex, or relay system application.

#### 4. Technical Characteristics

Types of operation.....	Voice (A3) (amplitude modulated) and fsk (F1) (radioteletype) simultaneously or independently, and cw (A1). (For fsk operation, additional radioteletype equipment is required but not supplied as part of the radio set.)
System application.....	Simplex, duplex, and relay.
Frequency range:	
Transmitter .....	1.5 to 20.0 mc.
Receiver .....	0.5 to 32.0 mc.
Method of tuning.....	Manual or automatic (7 pre-set channels).

Reliable distance range. 50 miles.  
 Types of antenna ..... 50-ohm unbalanced antenna,  
 15-foot whip, or trans-  
 former-fed doublet.

Radiated power with 15-  
 50-ohm antenna or  
 transformer-fed  
 doublet ..... 1.5 to 12.0 mc—100 watts.  
 12.0 to 16.0 mc— 90 watts.  
 16.0 to 20.0 mc— 80 watts.

Radiated power with 15-  
 foot whip antenna ..... 1.5 to 2.0 mc— 13 watts.  
 2.0 to 3.0 mc— 28 watts.  
 3.0 to 4.0 mc— 45 watts.  
 4.0 to 5.0 mc— 60 watts.  
 5.0 to 6.0 mc— 90 watts.  
 6.0 to 9.0 mc—100 watts.  
 9.0 to 16.0 mc— 90 watts.  
 16.0 to 20.0 mc— 80 watts.

Remote control  
 facilities ..... Keying control.  
 Audio input and output.

Selects one of seven preset  
 frequencies,  
 Fsk operation.  
 (Remote control of the trans-  
 mitter is provided when the  
 transmitter is used in con-  
 junction with auxiliary  
 equipment — Transmitter  
 Control C-822/GRC-19  
 and Cable Assembly, Special  
 Purpose, Electrical  
 CX-2585/U.)

Primary input  
 voltage ..... 22 to 30 volts dc. (For best  
 results, 28.5 volts.)

Maximum primary current  
 drain:  
 Starting surge..... 250 amperes.  
 Operating ..... 44 amperes.  
 Standby ..... 9 amperes.  
 Weight ..... 253½ pounds.

## 5. Components of Radio Set AN/GRC-19

a. Components (fig. 1).

Quantity	Item	Height (in.)	Depth (in.)	Width (in.)	Unit weight (lb)
1	Transmitter, Radio T-195 (*)/GRC-19, including: 1 Cable Assembly, Power, Electrical CX-2583/U. 1 Case, Electron Tube CY-1451/GRC-19..... 1 filter assembly, dust, auxiliary..... 1 Maintenance Kit, Electronic Equipment MK-312/GRC-19. 2 Technical Manuals TM 11-806..... 1 set of running spares (c below) .....	11 ½	14 ½	22 10 ft 10 ½	125 2 ½ 2 ..... ..... .....
1	Receiver, Radio R-392/URR, including: 1 Case, Electron Tube CY-1298/URR..... 2 Technical Manuals TM 11-858..... 1 Set of running spares (d below).....	11 ½	11 ¼	14 3/16 10 ½	52 ½ 2 .....
1	Mounting MT-851/GRC-19.....	1 11/16	14 9/32	33 ¾	45
1	Cable Assembly, Special Purpose, Electrical CX-1599/U.	.....	.....	9	15 oz
1	Cable Assembly, Radio Frequency CG-1127/U.....	.....	.....	10	6 oz
2	Cable Assembly, Special Purpose, Electrical CX-1852/U.	.....	.....	78	5 oz
3	Mast Sections MS-116-A.....	.....	.....	39 ½	4 oz
1	Mast Section MS-117-A.....	.....	.....	39 ½	2 oz
1	Mast Section MS-118-A.....	.....	.....	39 ½	1 oz
1	Mast Base MP-65-B.....	3 ¼	3 ¼	17 ½	2 ½
1	Cover, antenna.....	46 ¾	1 ½	1 ½	2
1	Antenna, sheath clamp.....	.....	.....	.....	.....
1	Terminal guard, antenna.....	1 ¼	1 ½	1 5/8	7/8 oz
1	Microphone M-29/U.....	4 ½	8 ½	1 5/8	14 oz
1	Key, Telegraph KY-116/U.....	4 ¼	2	5 ½	1
1	Headset, Electrical (Navy type 49507A).....	6 ¼	5	7 ¼	11 oz
2	Headset Cord, CX-1334/U.....	.....	.....	39	4 oz
1	Insulator IN-86.....	1 ½	4 ½	3 ½	3 oz
1	Rope RP-5.....	.....	.....	25 ft	6 oz
1	Wire W-146.....	.....	.....	6 ft	5 oz
1	Bag CW-206/GR.....	3	5	40	3 ½
2	TM 11-5820-295-10.....	.....	.....	.....	.....
1	Set of running spares (b below).....	.....	.....	.....	.....



b. *Radio Set AN/GRC-19 Running Spares.* The following running spares are packed with Radio Set AN/GRC-19:

Qty	Item
1	Headset, electrical (Navy type 49507A)
1	Insulator IN-86
1	Key, Telegraph KY-116/U
2	Mast Section MS-116-A
1	Mast Section MS-117-A
1	Mast Section MS-118-A
1	Microphone M-29/U

c. *Transmitter, Radio T-195/GRC-19 Running Spares.* The following running spares are packed with Transmitter, Radio T-195/GRC-19:

Qty	Item
2	Electron tubes, 4X150D
1	Electron tube, 5726/6AL5W
3	Electron tubes, 5749/6BA6W
2	Electron tubes, 5751
1	Electron tube, 5763
1	Electron tube, 5814A
2	Electron tubes, 6005/6AQ5/6095
2	Electron tubes, 6AK6
1	Electron tube, 6AU6WA
3	Electron tubes, 12AT7WA
1	Electron tube, 0A2WA
2	Dial lamps, miniature bayonet base, 28-volt, 0.175-ampere
6	Fuses, cartridge, 10-ampere, 32-volt
6	Fuses, cartridge, 15-ampere, 32-volt
6	Fuses, cartridge, 30-ampere, 32-volt

d. *Receiver, Radio R-392/URR Running Spares.* The following running spares are packed with Receiver, Radio R-392/URR:

Qty	Item
10	Electron tubes, 6AJ5
1	Electron tube, 26FZ6
2	Electron tubes, 12AU7
3	Electron tubes, 26A6
1	Electron tube, 26D6
1	Electron, 26C6
6	Fuses, cartridge, 0.5-ampere, 250-volt
6	Fuses FU-25, 5-ampere
2	Lamp LM-38, 28-volt, 0.175-ampere

## 6. Nomenclature and Common Names

A list of nomenclature assignments for the

components of Radio Set AN/GRC-19 is given below. A common name is indicated after each item.

Nomenclature	Common name
Radio Set AN/GRC-19	Radio set
Transmitter, Radio T-195(*)/GRC-19	Transmitter
Receiver, Radio R-392/URR	Receiver
Mounting MT-851/GRC-19	Mounting
Mast Sections MS-116-A, MS-117-A, and MS-118-A, antenna cover, antenna sheath clamp, and Mast Base MP-65-B.	Whip antenna
Wire W-146	Wire
Microphone M-29/U	Microphone
Key, Telegraph KY-116/U	Telegraph key
Mast Base MP-65-B	Mast base
Mast Sections MS-116-A, MS-117-A, and MS-118-A.	Mast sections

## 7. Description of Radio Set AN/GRC-19

a. Radio Set AN/GRC-19 includes a receiver, transmitter, mounting, interconnecting cables, and a suitable antenna system. Figure 1 shows all the components of the radio set.

b. Receiver, Radio R-392/URR and Transmitter, Radio T-195 (\*)/GRC-19 are secured to Mounting MT-851/GRC-19, which normally is bolted to a vehicular mounting surface. Connections are made between the major units supported on the mounting and to a 28-volt source. Connections to the antenna system are made directly from the front panel of the transmitter.

c. For remote operation of the radio set, the transmitter is connected directly to Transmitter Control C-822/GRC-19 (fig. 24) through Cable Assembly, Special Purpose, Electrical CX-2585/U (fig. 25) (auxiliary equipment; refer to TM 11-806). Connections can also be made to frequency-shift-keyed equipment for radioteletype transmission and to frequency-shift converter equipment for radioteletype reception.

d. An antenna switching relay in the transmitter permits the same antenna to be used for both transmitting and receiving.

## 8. Description of Transmitter, Radio T-195(\*)/GRC-19 (fig. 2)

a. The main frame of the transmitter contains eight removable subchassis. An air

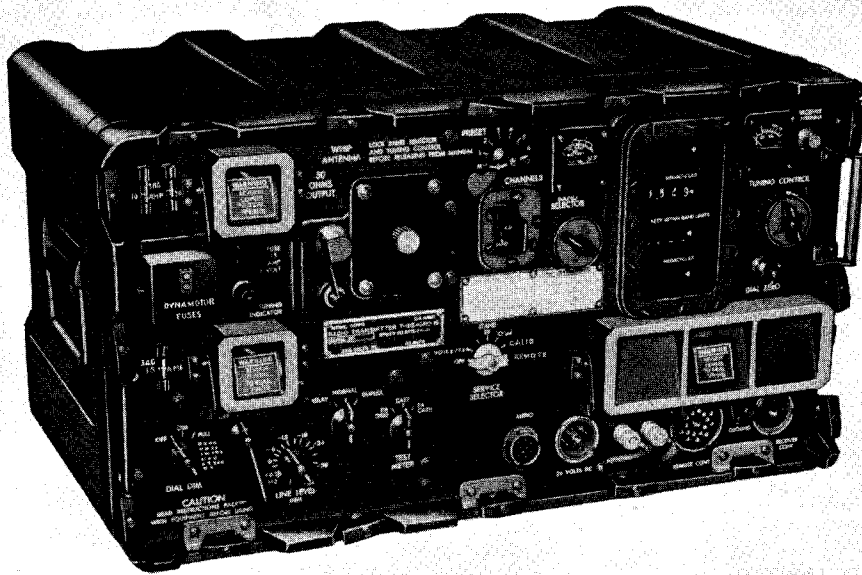

Figure 2. Transmitter, Radio T-195(\*)/GRC-19.

blower, relays, switches, and an electromechanical channel selector are also mounted on the main frame. Operating controls and receptacles are mounted on the front panel. Spring-loaded handles, one at each side of the case, are provided for carrying the transmitter. One handle at each end of the panel facilitates removal of the transmitter from its case. The transmitter case is recessed on the bottom rear to accommodate hooks for fastening the transmitter rigidly to its mounting. Thumbscrew clamps on the front of the mounting engage the lower edge of the transmitter front panel to firmly secure it to the mounting.

b. The transmitter is of ruggedized construction and can be made waterproof during transport or storage. Air intake and exhaust vents are used in a forced-air cooling system. When these vents are closed, the transmitter is waterproof.

**Caution:** The transmitter must not be operated with the air intake and exhaust vents closed. Before operating the transmitter, make sure that the air vents are open because damage to the equipment may result.

c. Operating frequency of the transmitter can be selected manually, or by an electromechanical channel selection system. The electromechanical system, known as Autotune,

automatically adjusts tuning elements in the transmitter to provide a preset operating frequency. Eight Autotune channels are available, one of which is designated for manual tuning. Each channel is preset to a desired channel frequency, after which it is only necessary to position a channel selector switch to obtain any of the preset channels.

d. Antenna tuning and loading of the power amplifier are accomplished automatically by the antenna tuning system.

## 9. Description of Receiver, Radio R-392/URR

(fig. 3)

a. The receiver consists of an upper and lower chassis into which are mounted six subchassis. The receiver fits into a waterproof case recessed on the bottom rear to accommodate hooks for fastening the receiver rigidly to its mounting. In addition, two thumbscrew clamps on the mounting engage the lower edge of the receiver front panel to firmly secure it to the mounting.

b. The front panel and subchassis are interconnected by cables. Operating controls and receptacles are mounted on the front panel. Spring-loaded handles, one on each side of the case, are provided for carrying the receiver.

## 10. Description of Minor Components

Special features of some of the minor components are described below:

a. The whip antenna (fig. 4) consists of three Mast Sections MS-116-A, one Mast Section MS-117-A, one Mast Section MS-118-A, one Mast Base MP-65-B, one cover, antenna and one antenna sheath clamp. The mast sections are screwed together, and the assembly is screwed to the mast base which mounts on a rigid support. The antenna cover is mounted over the lower mast section (Mast Section MS-116-A) and fastened in place with the antenna sheath clamp. Connection between the transmitter and a binding post on the mast base is made with Wire W-146.

b. Mounting MT-851/GRC-19 (fig. 5) serves as a support for the transmitter and receiver. At both ends of the mounting are two shock-mounted supports which normally are bolted to a vehicular mounting surface. Two grounding straps, one at the rear of each end, are provided for grounding the mounting (not shown). Six fixed position clamps on the top

rear of the mounting are used to hold securely the rear of the transmitter and receiver. Five pressure adjustable clamps on the front of the mounting secure the front of the equipment.

c. Microphone M-29/U (fig. 6) consists of a 100-ohm carbon element in a plastic case with push-to-talk switch and connecting cord attached. The push-to-talk switch is a two position nonlocking switch. The connecting cord is 5 feet long and terminates in a 10-pin audio connector. This connector will mate with the AUDIO receptacle on the transmitter, receiver, or a remote control unit (Transmitter Control C-822/GRC-19).

d. Headset, Electrical (Navy type 49507A) (fig. 7) consists of two series-connected 300-ohm receivers. A 14-inch cord is connected to the receivers and terminated in Plug PL-54. The plug will mate with Jack JK-26 on one end of Headset Cord CX-1334/U (fig. 9). Headset Cord CX-1334/U terminates in a 10-pin audio connector which mates with the AUDIO receptacle on the transmitter, receiver, or remote control unit.

e. Key, Telegraph KY-116/U (fig. 8) is at-

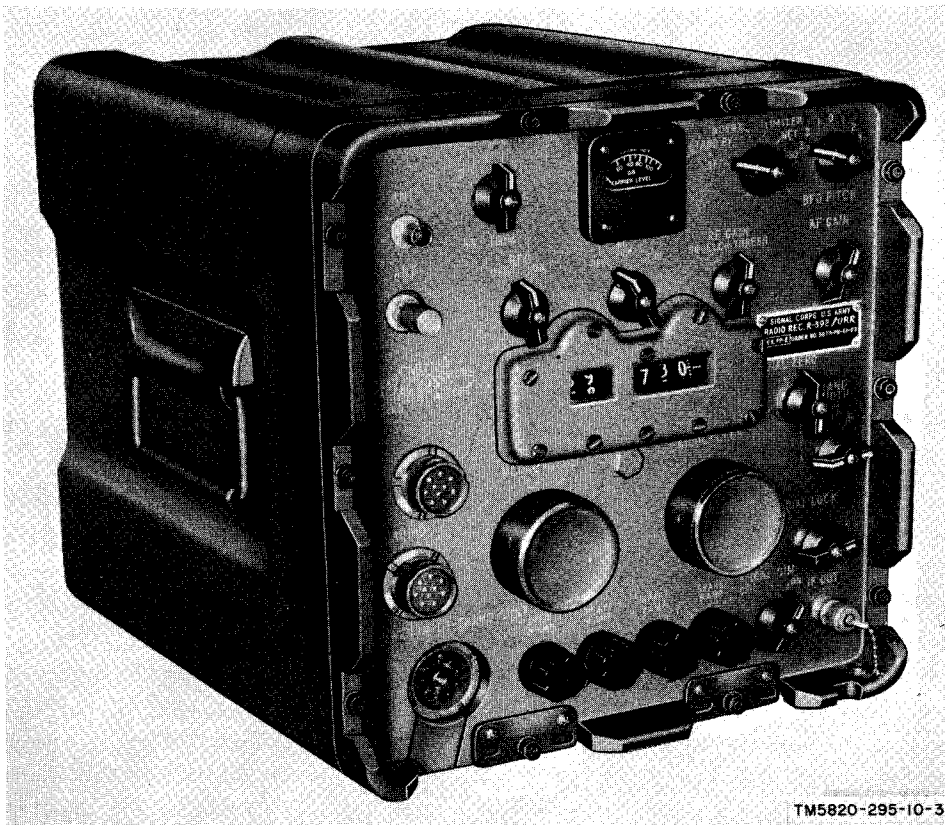

Figure 3. Receiver, Radio R-392/URR.

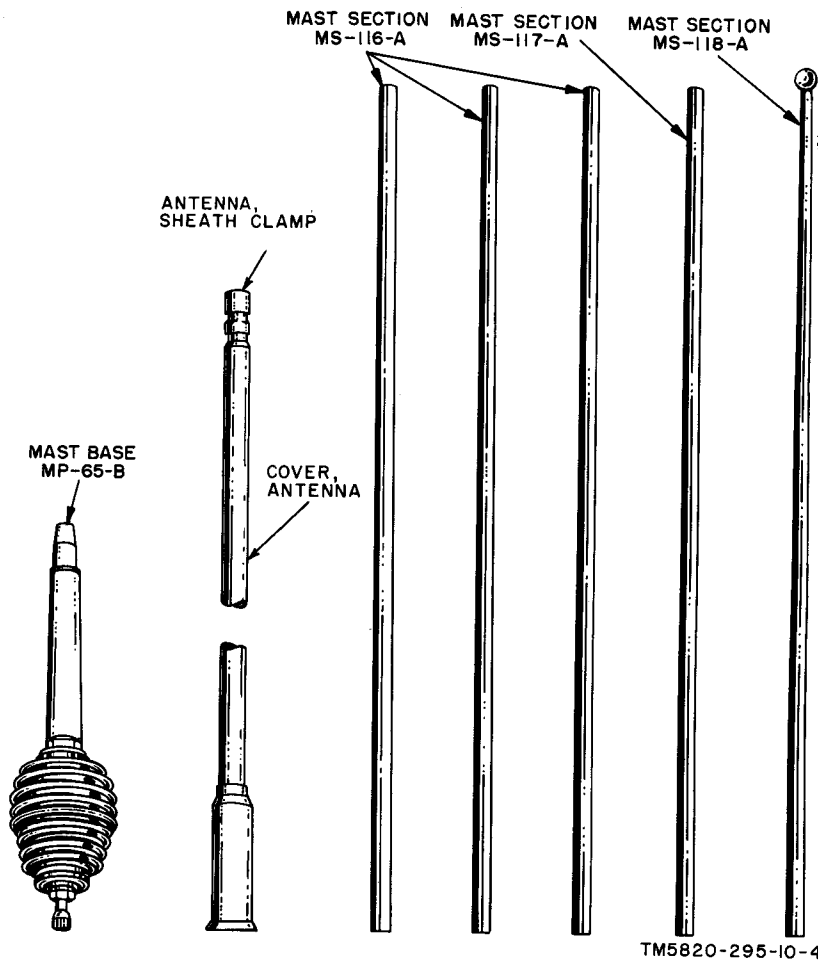

Figure 4. Whip antenna.

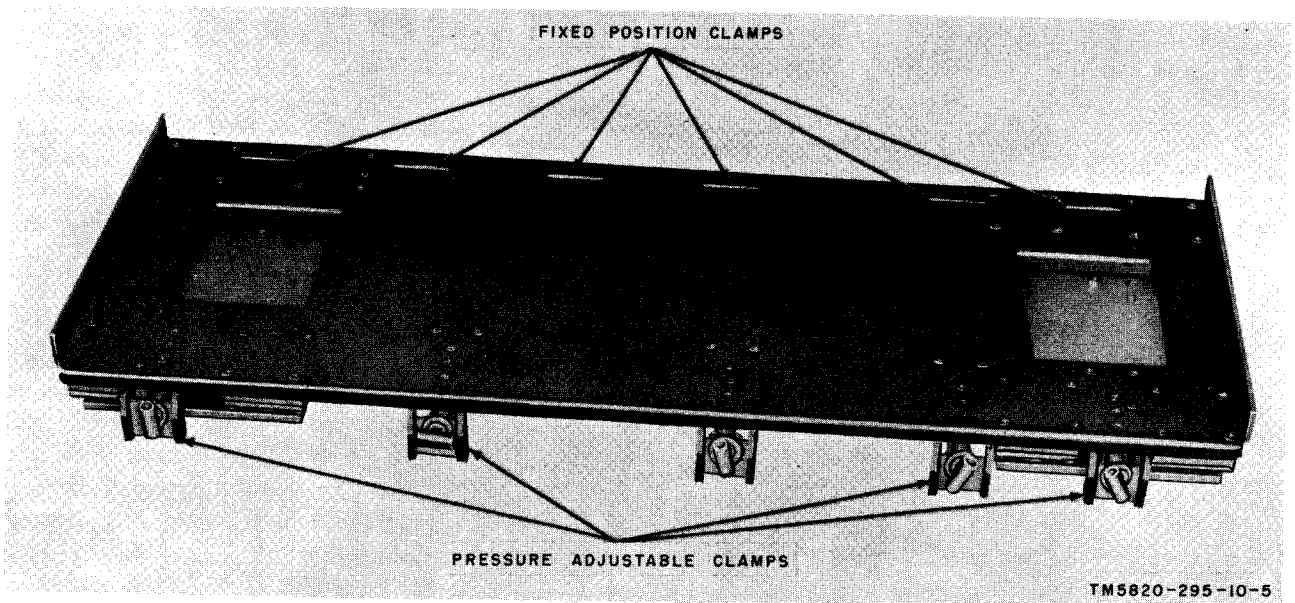
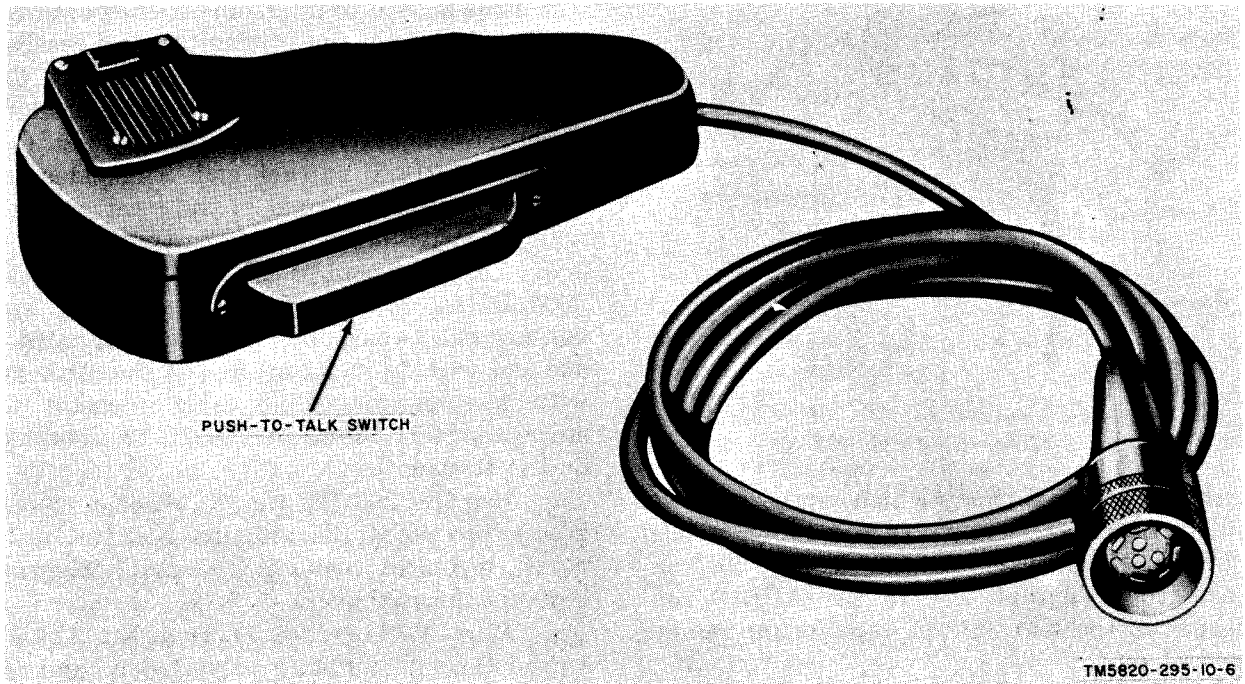

Figure 5. Mounting MT-851/GRC-19.



PUSH-TO-TALK SWITCH

TM5820-295-10-6

Figure 6. Microphone M-29/U.

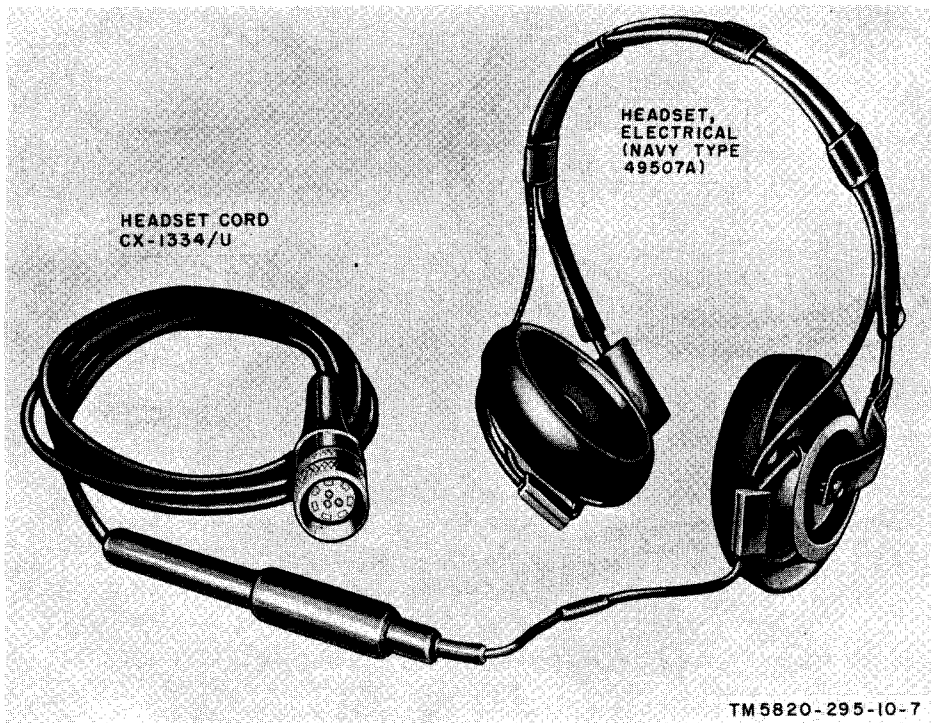

HEADSET CORD  
CX-1334/U

HEADSET,  
ELECTRICAL  
(NAVY TYPE  
49507A)

TM5820-295-10-7

Figure 7. Headset, Electrical (Navy type 49507A) and Headset Cord CX-1334/U.

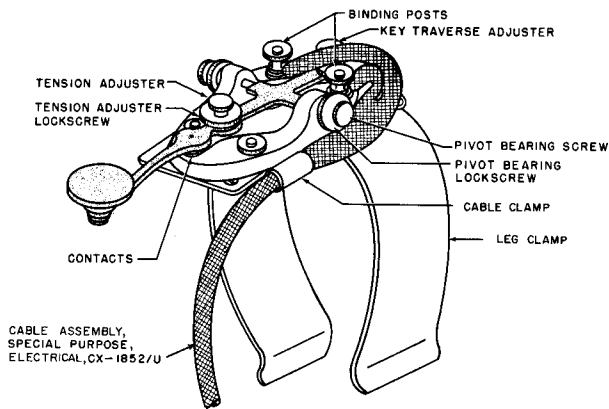

TM5820-295-10-8

Figure 8. Key, Telegraph KY-116/U.

tached to a metal clamp which can be mounted on the operator's leg. Cable Assembly, Special Purpose, Electrical CX-1852/U (fig. 9) connects the telegraph key to the AUDIO connector on the transmitter, receiver, or remote control unit.

f. Cable Assembly, Special Purpose, Electrical CX-1599/U (fig. 9) is a heavy-duty, rubber-covered, eight-conductor cable with a

nine-pin, right-angle connector on each end. The cable is used to interconnect the power and control circuits of the transmitter and receiver.

g. Cable Assembly, Radio Frequency CG-1127/U (fig. 9) consists of a length of Radio Frequency Cable RG-58C/U with Plug Connector UG-913/U on each end. This cable connects the antenna circuit of the receiver to the antenna switching relay of the transmitter.

h. Cable Assembly, Power, Electrical CX-2583/U (fig. 9) is a 10-foot, heavy-duty, rubber-covered, two-conductor cable terminated at one end with  $\frac{3}{8}$ -inch lugs and at the other end with a connector. This cable connects the storage battery to the 24 VOLTS DC connector on the transmitter.

i. Bag CW-206/GR (fig. 1), made of canvas, is used to store the antenna sections, spare parts, technical manuals, headset, telegraph key, and microphone.

j. Wire W-146 (fig. 1) is a No. 12AWG stranded conductor with polyethylene and cotton-braid insulation. The wire is used to connect the whip antenna to the transmitter.

k. Insulator IN-86 is a rectangular, ceramic

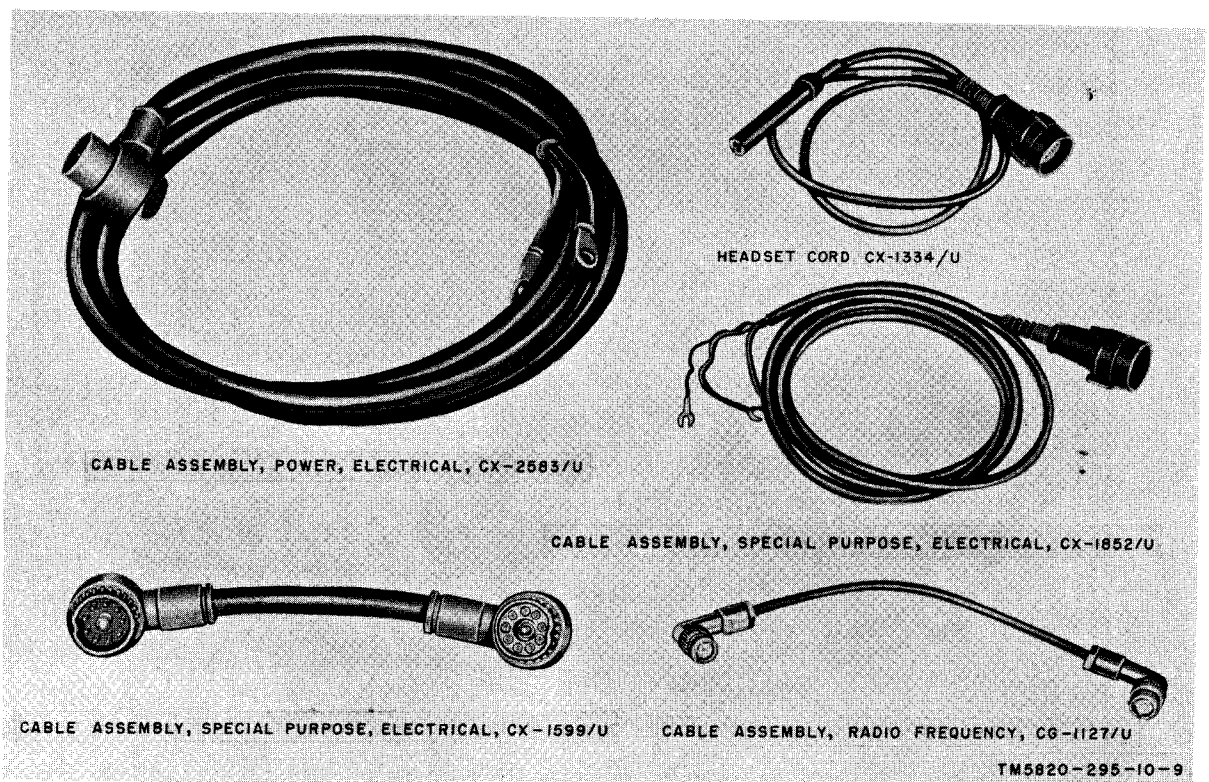
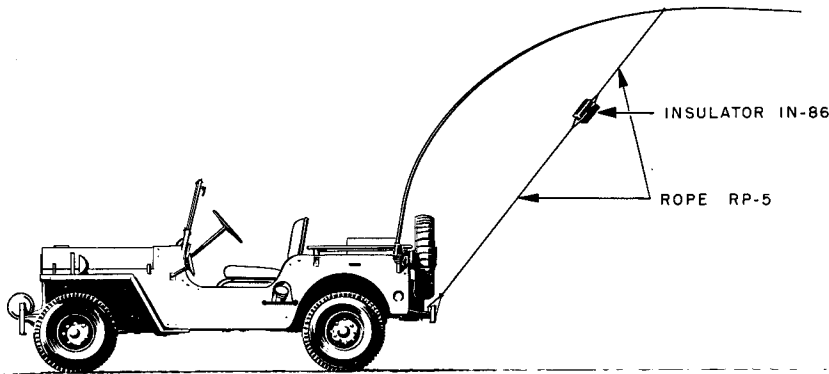

Figure 9. Cable assemblies.



TM5820-295-10-10

Figure 10. Whip antenna tiedown with Rope RP-5 and Insulator IN-86.

insulator used to insulate the whip antenna from tiedown Rope RP-5 (fig. 10).

l. The antenna cover (fig. 11) is a polyethylene, antenna insulating sheath which covers the lower portion of the antenna. Operating personnel who accidentally come into contact with the lower mast sections of the antenna are protected by the sheath from receiving rf burns.

m. The antenna, sheath clamp (fig. 11) fits on the top of the antenna cover and clamps the antenna cover in place.

## 11. Additional Equipment Required

A 28-volt storage battery is required for use with the transmitter. The battery also supplies voltage for the receiver.

## 12. System Application

Radio Set AN/GRC-19 was designed primarily for vehicular installation; however, it can also be used as a fixed-portable installation. When the radio set is used as a fixed-portable station, an antenna group may be used to increase its range. (Radio Set AN/GRC-19 may be used with Antenna Group AN/GRA-12 described in TM 11-2651.) Transmission and reception of cw and voice signals, and also of fsk radioteletype signals are possible with either type of installation. The transmitter may be remotely controlled from a distance up to 75 feet through the use of auxiliary equipment. (Refer to chapter 5.) Three types of system application are possible: simplex, duplex, and relay. During relay application, CW, FSK, or VOICE/FSK operation is seldom used. The operation is usually by voice signals.

a. *Simplex* (fig. 12). One antenna is used for either receiving or transmitting. When the radio set is transmitting, the receiver is not operating, and the antenna is used only for transmission of radio signals. For reception of radio signals, the transmitter is switched off, the antenna is switched to the receiver, and the receiver is made operable. The radio set either transmits or receives at any one time. Trans-

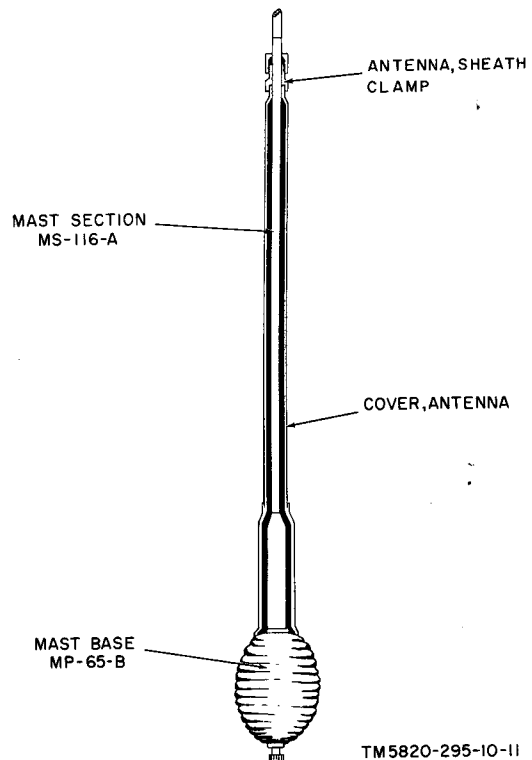

TM5820-295-10-11

Figure 11. Antenna cover and sheath clamp mounted on Mast Section MS-116-A.

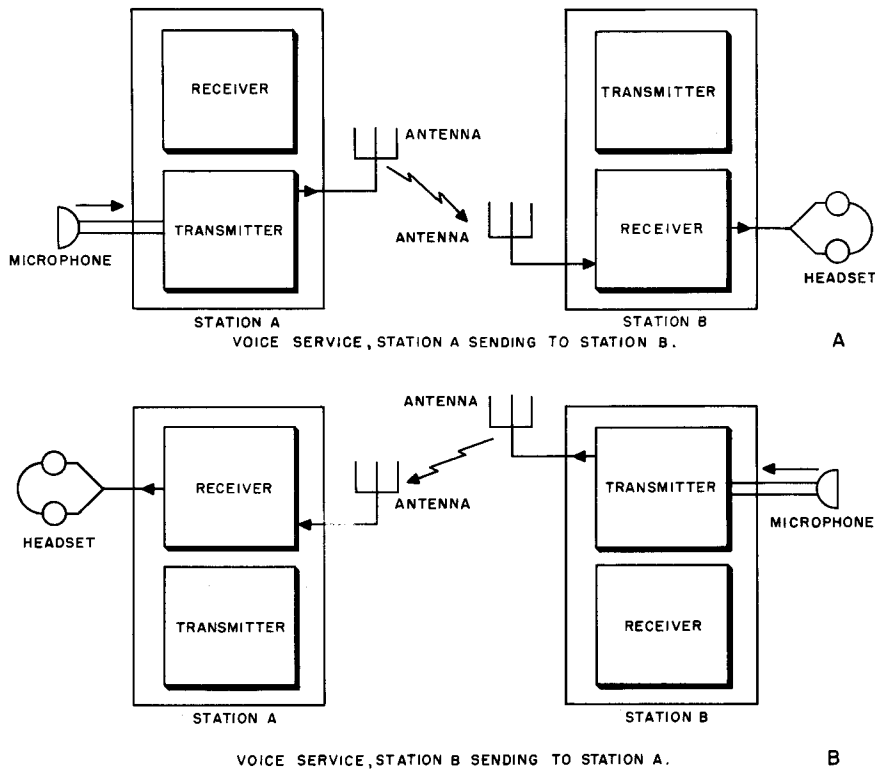

TM5820-295-10-12

Figure 12. Simplex voice service, simplified block diagram.

mitting and receiving may be done on the same frequency or on two different frequencies. A, figure 12, shows a voice signal being transmitted from station A to the receiver at station B; B, figure 12, shows station A receiving a signal from station B.

b. *Duplex.* Duplex voice operation of the radio set is illustrated in figure 13. Two antennas are required for duplex operation: one

for receiving and the other for transmitting. During duplex operation, it is possible to receive and send at the same time, provided that the receiver and transmitter are tuned to different frequencies. The frequencies must be separated far enough to avoid blocking and interference to the receiver by its station transmitter.

c. *Relay.* Relay operation may be either

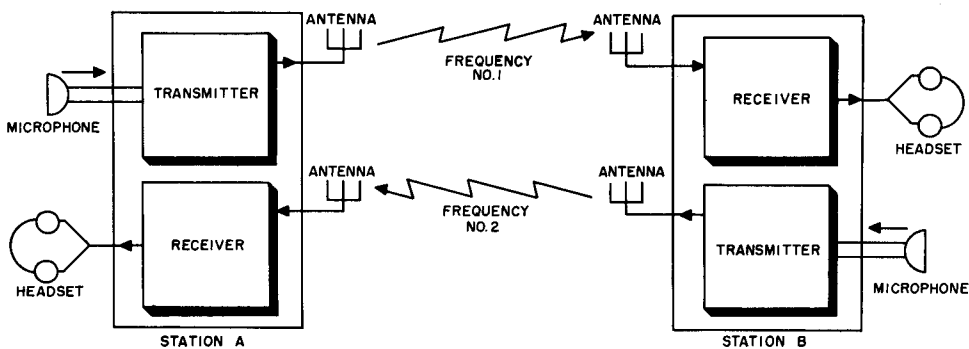

TM5820-295-10-13

Figure 13. Duplex voice operation, simplified block diagram.



simplex (fig. 14) or duplex. The receiver and transmitter frequencies must be separated sufficiently to avoid blocking and interference to the receiver.

- (1) Simplex operation requires two antennas: one for receiving and the other for transmitting. In A, figure 14, the voice signals from station A are being relayed by the relay station to station B. In B, the voice signals from station B are being relayed to

station A. Transmission is only in one direction at a time.

- (2) Duplex operation (C, fig. 14) permits receiving and transmitting at the same time. For this type of operation, two transmitters, two receivers, and four antennas are required.

d. Remote control.

- (1) Remote control of Transmitter, Radio T-195(\*)/GRC-19 (fig. 15) at distances up to 75 feet is possible when

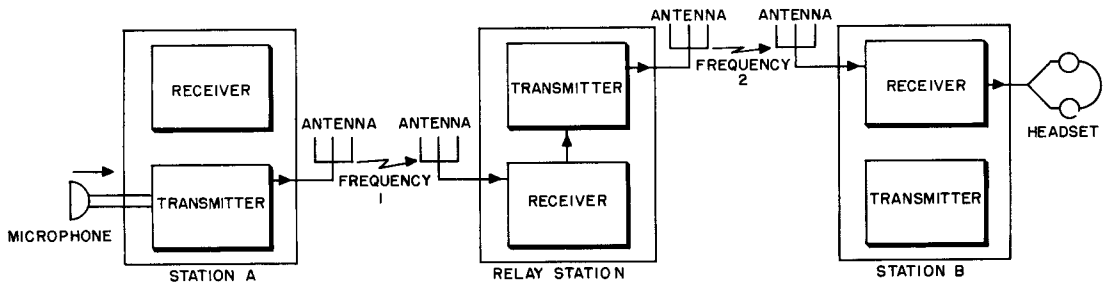

SIMPLEX RELAY, VOICE SERVICE, STATION A SENDING TO STATION B.

A

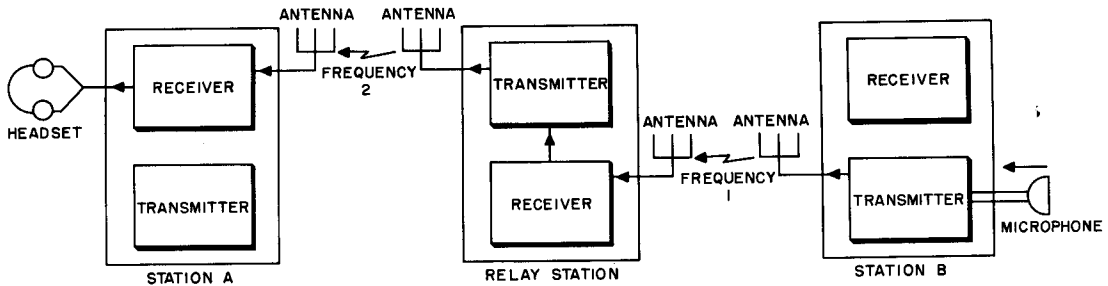

SIMPLEX RELAY, VOICE SERVICE, STATION B SENDING TO STATION A.

B

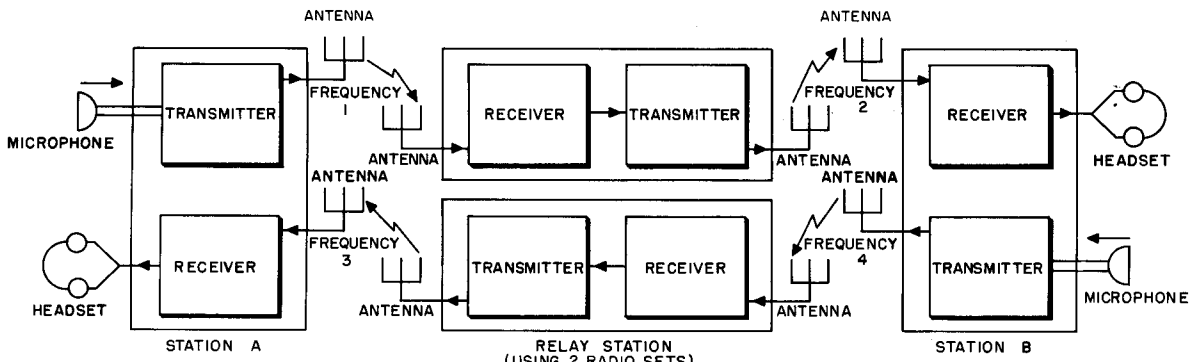

DUPLEX RELAY, VOICE SERVICE, STATION A AND STATION B SENDING AND RECEIVING AT THE SAME TIME.

C

TM5820-295-10-14

Figure 14. Relay voice service, simplified block diagram.

the transmitter is used in conjunction with Transmitter Control C-822/GRC-19 (fig. 24) and Cable Assembly, Special Purpose, Electrical CX-2585/U (fig. 25) (auxiliary equipment).

- (2) Transmitter Control C-822/GRC-19 can turn the transmitter on and off, select the type of operation (OFF, CW, STAND BY, FSK/VOICE), select any one of seven preset trans-

mitter frequencies, and indicate when the transmitter is ready for operation.

- (3) In addition to voice and cw transmission and reception from a remote control point, voice and cw transmission and reception are also possible at the transmitter and receiver when an additional microphone, telegraph key, and a headset are used.

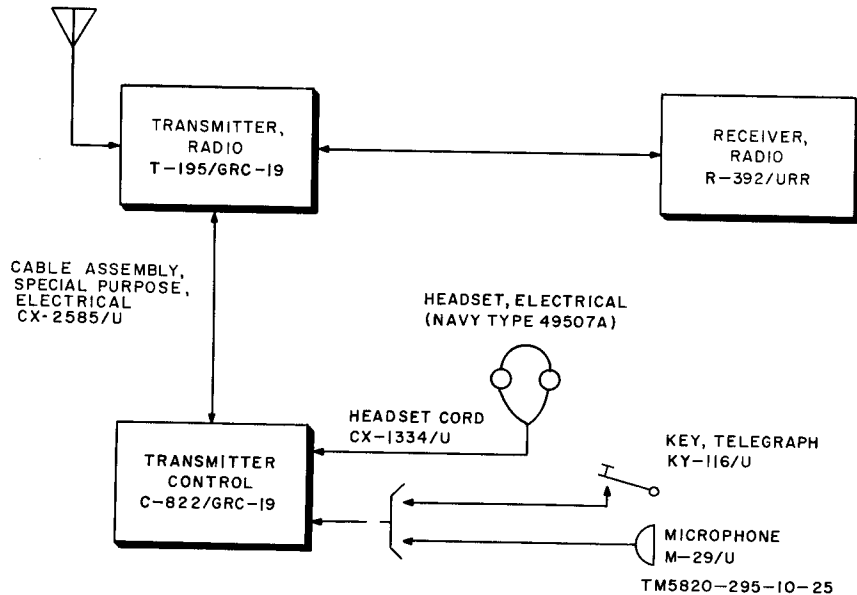

Figure 15. Radio Set AN/GRC-19, with Transmitter Control C-822/GRC-19 and Cable Assembly, Special Purpose, Electrical CX-2585/U, block diagram.

## CHAPTER 2 INSTALLATION

### 13. Unpacking

a. *Packaging Data.* When packed for shipment, the components of Radio Set AN/GRC-19

are placed in cartons and packed in four wooden boxes. A typical shipping box and its contents are shown in figure 16.

Box No.	Height (in.)	Width (in.)	Depth (in.)	Volume (cu ft)	Unit weight (lb)	Contents of box
1	14 $\frac{3}{8}$	30 $\frac{3}{4}$	18 $\frac{1}{8}$	4.6	166	Transmitter, Radio T-195(*)/GRC-19
2	14 $\frac{1}{8}$	20 $\frac{1}{8}$	18 $\frac{3}{4}$	3.0	81	Receiver, Radio R-392/URR
3	8 $\frac{1}{2}$	43 $\frac{1}{2}$	11	2.4	37	Bag CW-206/GR and miscellaneous items
4	17	37 $\frac{1}{4}$	5 $\frac{1}{4}$	1.9	70	Mounting MT-851/GRC-19

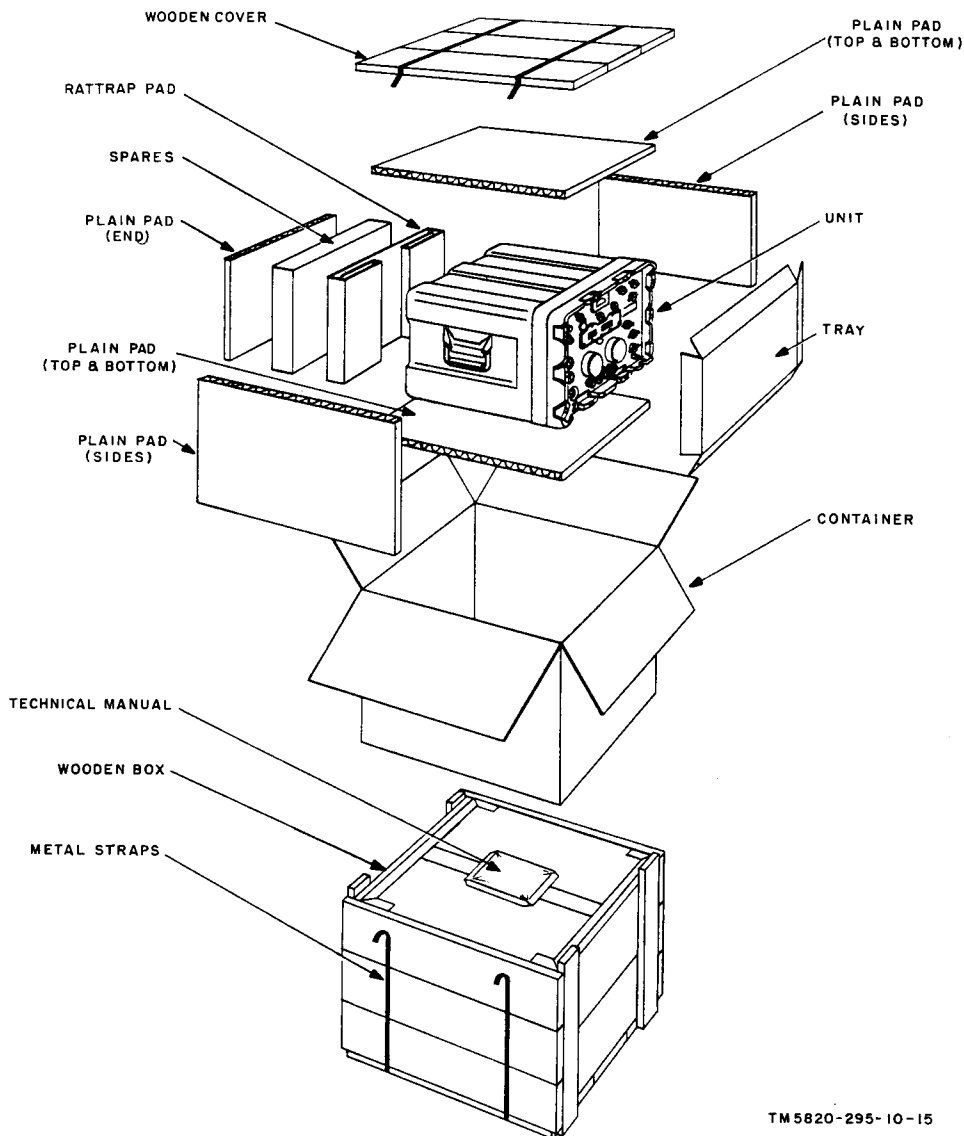

TM 5820-295-10-15

Figure 16. Typical packaging.

b. *Removing Contents.* Perform all the steps outlined below when unpacking Transmitter, Radio T-195(\*)/GRC-19, Receiver, Radio R-392/URR, and Bag CW-206/GR.

When unpacking Mounting MT-851/GRC-19, omit procedure (3) and (4) below.

- (1) Cut and fold back the metal straps.
- (2) Remove the nails from the top and one

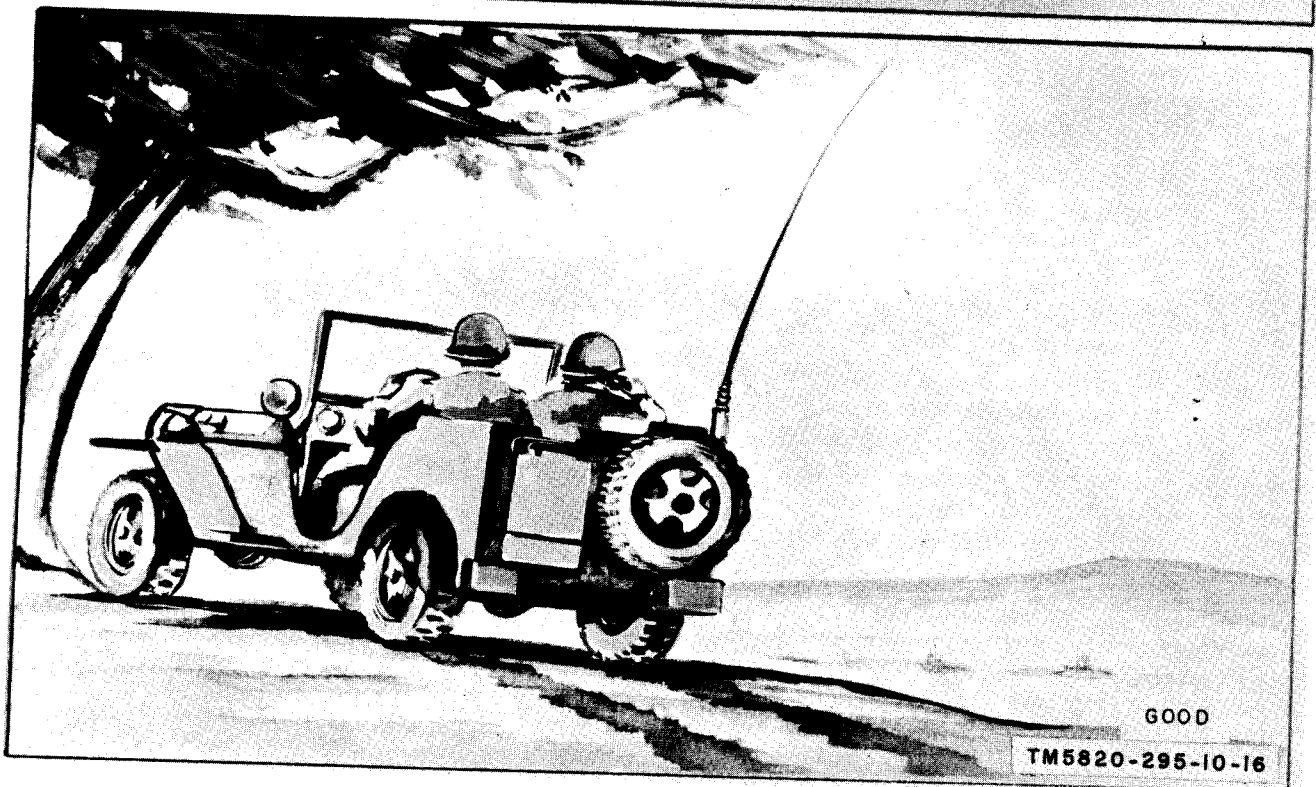
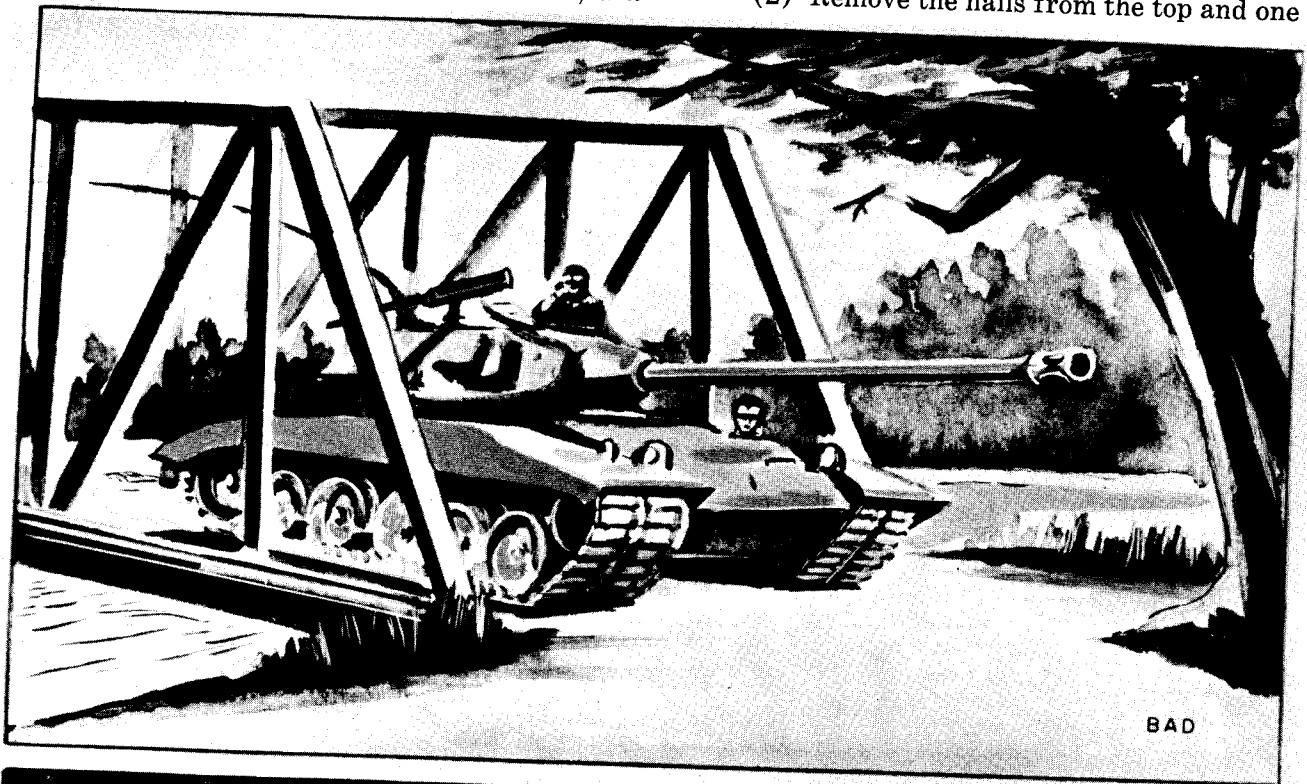

Figure 17. Good and bad operating locations.

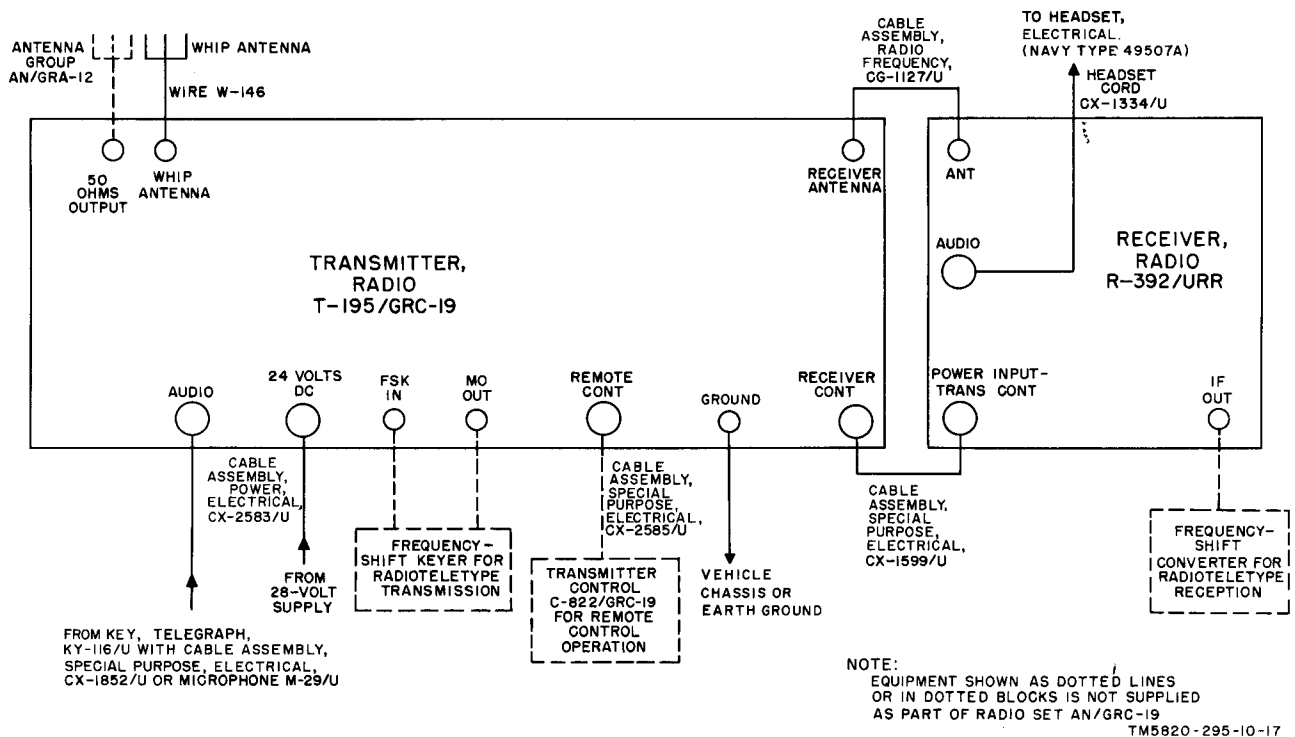

Figure 18. Radio Set AN/GRC-19 cording diagram simplex application.

side of the box with a nailpuller. Remove the top and one side. Do not attempt to pry them off, because the equipment may become damaged.

- (3) Remove the carton.
- (4) Open the carton.
- (5) Remove the contents.

#### 14. Checking Unpacked Equipment

a. Inspect the equipment for damage incurred during shipment. If the equipment has been damaged, refer to paragraph 2.

b. See that the equipment is complete as listed on the packing slip. If a packing slip is not available, check against the table of components (par. 5).

c. If the equipment has been used or reconditioned, see whether it has been changed by a modification work order (MWO). If modified, the MWO number will appear on the front panel near the nomenclature plate. Check to see that this MWO number also appears on the schematic diagram of the manual accompanying the equipment. If the number does not appear, add a note to the overall schematic diagram.

#### 15. Siting

When locating the antenna, consider the following:

a. The best location for the radio set depends on the tactical situation and on local conditions such as the need for camouflage, the type of vehicle, possible installation in a shelter, and the terrain.

b. Transmitted signals will have a greater range when the antenna is high and clear of hills, buildings, cliffs, and wooded areas. Valleys and other low places are poor locations for radio reception and transmission, because the surrounding high terrain absorbs the radio signals.

c. Clear, strong signals cannot be expected if the radio set is operated under, or close to, steel bridges, underpasses, powerlines, hospitals, or power units. If possible, choose a location on a hilltop or other high place. Examples of good and bad operating locations are shown in figure 17.

#### 16. Shelter Requirements

Provide a shelter with the facilities given

below if Radio Set AN/GRC-19 is to be used as a fixed-portable station.

a. Adequate drainage to prevent flooding the inside of the shelter.

b. The floorspace should include enough area for the equipment, including extensions such as doors, and aisle space between the equipment and the nearest obstructions. Allow enough space for operation and maintenance of the equipment.

## 17. Connections

For simplex application, connect the compo-

nents according to the cording diagram (fig. 18). For duplex or relay application, make the same connections as for simplex application except for connection of Cable Assembly, Radio Frequency CG-1127/U. Do not connect Cable Assembly, Radio Frequency CG-1127/U. Instead, connect an additional antenna (Antenna Group AN/GRA-12 or whip antenna) to the ANT connector of Receiver, Radio R-392/URR. The following chart lists the cable connections for simplex operation of Radio Set AN/GRC-19:

Cable	Required No.	Length (ft)	Connects			
			From		To	
			Equipment	Connector	Equipment	Connector
Rf transmission line (Part of Antenna Group AN/GRA-4)	1		Transmitter, Radio T-195(*)/GRC-19	50 OHMS OUTPUT	Antenna Group 12 AN/GRA-12 <sup>a</sup>	
Wire W-146 .....	1	6	Transmitter, Radio T-195(*)/GRC-19	WHIP ANTENNA	Whip antenna	
Cable Assembly, Radio Frequency CG-1127/U	1	10 in.	Transmitter, Radio T-195(*)/GRC-19	RECEIVER ANTENNA	Receiver, Radio R-392/URR	ANT
Cable Assembly, Special Purpose, Electrical CX-1599/U	1	9 in.	Transmitter, Radio T-195(*)/GRC-19	RECEIVER CONT	Receiver, Radio R-392/URR	POWER INPUT-TRANS CONT
Cable Assembly, Special Purpose, Electrical CX-2585/U <sup>a</sup>	1	75	Transmitter, Radio T-195(*)/GRC-19	REMOTE CONT	Transmitter Control C-822/GRC-19 <sup>a</sup>	J701
Cable Assembly, Power, Electrical CX-2583/U	1	10	Transmitter, Radio T-195(*)/GRC-19	24 VOLTS DC	28-volt supply	
Cable Assembly, Special Purpose, Electrical CX-1852/U	1	6½	Transmitter, Radio T-195(*)/GRC-19	AUDIO	Key, Telegraph KY-116/U	
Microphone cable <sup>b</sup>	1		Transmitter, Radio T-195(*)/GRC-19	AUDIO	Microphone M-29/U	
Headset Cord CX-1334/U	1	39 in.	Transmitter, Radio T-195(*)/GRC-19	AUDIO	Headset, Electrical (Navy type 49507A)	
Hookup wire .....			Transmitter, Radio T-195(*)/GRC-19	GROUND	Vehicle chassis or earth ground	

Cable	Required No.	Length (ft)	Connects			
			From		To	
			Equipment	Connector	Equipment	Connector
Rf cable .....	1		Transmitter, Radio T-195(*)/GRC-19	MO OUT	Auxiliary radiotele- type equipment	
Rf cable .....	1		Transmitter, Radio T-195(*)/GRC-19	FSK IN	Auxiliary radiotele- type equipment	
Rf cable .....	1		Receiver, Radio R-392/URR	IF OUT	Auxiliary radiotele- type equipment	

<sup>a</sup> Auxiliary equipment; not supplied with the radio set.

<sup>b</sup> The microphone cable is an integral part of Microphone M-29/U.

*Note.* For FSK operation, additional cable connections will have to be made internally in the transmitter. Higher echelon personnel are required to make these connections.

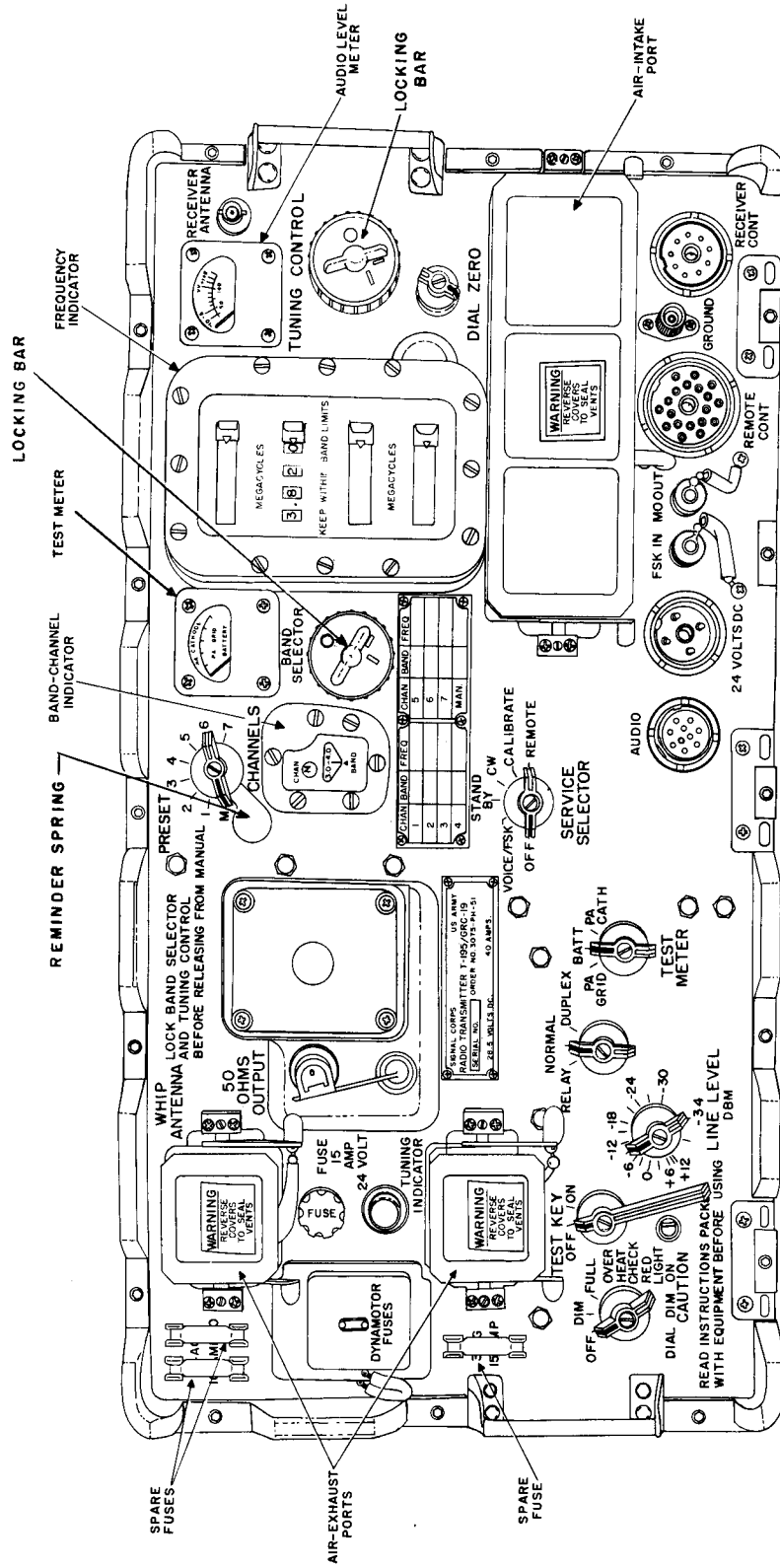

TM 5820-295-10-18

Figure 19. Transmitter, Radio T-195(\*)/GRC-19, controls and indicators.



# CHAPTER 3

## OPERATING INSTRUCTIONS

### Section I. OPERATOR'S CONTROLS AND INDICATORS

*Note.* This section covers only controls and indicators used *by the operator*; those used by maintenance personnel are covered in instructions for the appropriate maintenance echelon.

#### 18. Damage from Improper Settings

Take the following precautions when setting the controls:

a. Do not turn the transmitter SERVICE SELECTOR switch to OFF while the Autotune system is cycling.

b. Be careful when setting the receiver MEGACYCLES control. On some sets, the stop mechanism fails to provide a positive stop. The limits between which this control may be rotated without damage are 00 and 31 mc.

c. Be careful when setting the receiver KILOCYCLES control. It can be tuned through 000 kc in the counterclockwise direction for 15 kc, in which case the counter will indicate 975. It is also possible to tune 999 kc in the clockwise direction for 25 kc, in which case the counter will indicate 025. The limits between which this control may be rotated without jamming and damage are 000 and 999 kc.

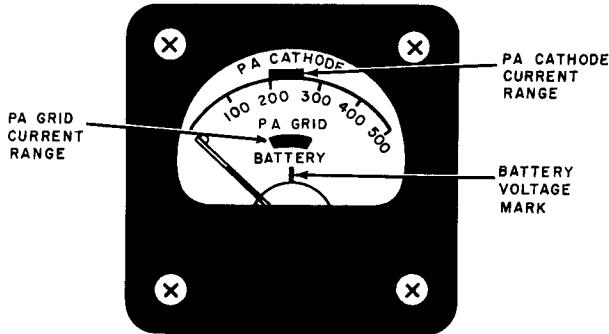

TM5820-295-10-27

Figure 20. Transmitter test meter.

#### 19. Transmitter, Radio T-195(\*)/GRC-19, Controls and Indicators (fig. 19)

Control or indicator	Function
SERVICE SELECTOR switch .....	Selects any one of six methods of transmitter condition:
<i>Sw pos</i>	<i>Result</i>
OFF	Turns transmitter off.
VOICE/FSK	Provides operation for simultaneous or independent transmission of frequency-shift-keyed radioteletype (F1) or amplitude-modulated (A3) signals.
STAND BY	Makes transmitter inoperative. (Blowers and tube filaments remain on.)
CW	Provides operation for transmission of continuous-wave (A1) signals.
CALIB	Allows calibration of transmitter.
REMOTE	Allows operation of transmitter from a remote position (when auxiliary equipment is used).
RELAY-NORMAL-DUPLEX switch .....	Selects any one of three methods of system application:
<i>Sw pos</i>	<i>System application</i>
RELAY	Relay station.
NORMAL	Simplex station.
DUPLEX	Duplex station.
BAND indicator .....	Indicates any one of 10 frequency bands selected by the BAND SELECTOR switch.
CHAN indicator .....	Indicates any one of eight channels selected by the BAND SELECTOR switch.

Control or indicator	Function										
Frequency indicator .....	Indicates transmitter operating frequency.										
BAND SELECTOR switch .....	Selects any one of 10 frequency bands as indicated on the BAND indicator, and selects any one of 8 channels as indicated on the CHAN indicator simultaneously.										
BAND SELECTOR switch locking bar .....	Locks the BAND SELECTOR switch.										
TUNING CONTROL .....	Tunes the transmitter.										
TUNING CONTROL locking bar .....	Locks the TUNING CONTROL.										
DIAL ZERO control .....	Calibrates frequency indicator.										
PRESET CHANNELS switch .....	Selects any one of seven preset channels or one manual channel.										
Reminder spring .....	Locks PRESET CHANNELS switch in M (manual) position.										
Test meter .....	Indicates current or voltage (fig. 20) in circuit selected by TEST METER switch.										
TEST METER switch .....	Selects any one of three circuits for connection to the test meter.										
	<table border="0"> <tr> <td style="text-align: center;"><i>Sw pos</i></td> <td style="text-align: center;"><i>Circuit selected</i></td> </tr> <tr> <td>PA GRID</td> <td>Power amplifier grid.</td> </tr> <tr> <td>BATT</td> <td>Battery.</td> </tr> <tr> <td>PA CATH</td> <td>Power amplifier cathode.</td> </tr> </table>	<i>Sw pos</i>	<i>Circuit selected</i>	PA GRID	Power amplifier grid.	BATT	Battery.	PA CATH	Power amplifier cathode.		
<i>Sw pos</i>	<i>Circuit selected</i>										
PA GRID	Power amplifier grid.										
BATT	Battery.										
PA CATH	Power amplifier cathode.										
Audio level meter .....	Indicates modulator output.										
LINE LEVEL DBM control .....	Adjusts level of signal from receiver during relay operation.										
TEST KEY switch .....	Turns transmitter on and off.										
TUNING INDICATOR .....	Indicates condition of automatic tuning cycle (lights when tuning cycle is completed).										
DIAL DIM switch .....	Selects any one of four conditions for the dial lamps and TUNING INDICATOR.										
	<table border="0"> <tr> <td style="text-align: center;"><i>Sw pos</i></td> <td style="text-align: center;"><i>Condition</i></td> </tr> <tr> <td>OFF</td> <td>Off.</td> </tr> <tr> <td>DIM</td> <td>Dimly lighted.</td> </tr> <tr> <td>FULL</td> <td>Maximum brightness.</td> </tr> <tr> <td>OVERHEAT CHECK RED LIGHT ON</td> <td>Lights when there is a thermal overload.</td> </tr> </table>	<i>Sw pos</i>	<i>Condition</i>	OFF	Off.	DIM	Dimly lighted.	FULL	Maximum brightness.	OVERHEAT CHECK RED LIGHT ON	Lights when there is a thermal overload.
<i>Sw pos</i>	<i>Condition</i>										
OFF	Off.										
DIM	Dimly lighted.										
FULL	Maximum brightness.										
OVERHEAT CHECK RED LIGHT ON	Lights when there is a thermal overload.										

## 20. Receiver, Radio R-392/URR, Controls and Indicators (fig. 21)

Control or indicator	Function														
Function switch .....	Selects any one of six methods of receiver condition.														
	<table border="0"> <tr> <td style="text-align: center;"><i>Sw pos</i></td> <td style="text-align: center;"><i>Result</i></td> </tr> <tr> <td>OFF</td> <td>Turns receiver off.</td> </tr> <tr> <td>STAND BY</td> <td>Makes receiver inoperative. (Tube filaments remain on.)</td> </tr> <tr> <td>NORMAL</td> <td>Receiver operative without noise limiting and squelch.</td> </tr> <tr> <td>LIMITER</td> <td>Reduces received noise.</td> </tr> <tr> <td>NET</td> <td>Allows simultaneous operation of receiver and transmitter.</td> </tr> <tr> <td>SQ</td> <td>Makes audio circuit inoperative unless a signal is being received.</td> </tr> </table>	<i>Sw pos</i>	<i>Result</i>	OFF	Turns receiver off.	STAND BY	Makes receiver inoperative. (Tube filaments remain on.)	NORMAL	Receiver operative without noise limiting and squelch.	LIMITER	Reduces received noise.	NET	Allows simultaneous operation of receiver and transmitter.	SQ	Makes audio circuit inoperative unless a signal is being received.
<i>Sw pos</i>	<i>Result</i>														
OFF	Turns receiver off.														
STAND BY	Makes receiver inoperative. (Tube filaments remain on.)														
NORMAL	Receiver operative without noise limiting and squelch.														
LIMITER	Reduces received noise.														
NET	Allows simultaneous operation of receiver and transmitter.														
SQ	Makes audio circuit inoperative unless a signal is being received.														

Control or indicator	Function								
AGC switch .....	Selects any one of three positions: <table border="0"> <tr> <td><i>Sw pos</i></td> <td><i>Result</i></td> </tr> <tr> <td>OFF</td> <td>Turns off automatic adjustment of receiver gain.</td> </tr> <tr> <td>ON</td> <td>Allows automatic adjustment of receiver gain.</td> </tr> <tr> <td>CAL</td> <td>Allows calibration of frequency indicator dial.</td> </tr> </table>	<i>Sw pos</i>	<i>Result</i>	OFF	Turns off automatic adjustment of receiver gain.	ON	Allows automatic adjustment of receiver gain.	CAL	Allows calibration of frequency indicator dial.
<i>Sw pos</i>	<i>Result</i>								
OFF	Turns off automatic adjustment of receiver gain.								
ON	Allows automatic adjustment of receiver gain.								
CAL	Allows calibration of frequency indicator dial.								
AF GAIN control .....	Adjusts audio level at the headset.								
RF GAIN SQUELCH THRESH control ....	Adjusts audio level at the headset by controlling the strength of the received signal when the function switch is in NORMAL LIMITER, or NET position. Establishes the minimum required signal strength to make the receiver operable when the function switch is set to SQ.								
BFO switch .....	Turns beat-frequency oscillator on and off.								
BFO PITCH control .....	Adjusts tone of beat-frequency oscillator.								
BAND WIDTH switch .....	Selects any one of three selectivity conditions: <table border="0"> <tr> <td><i>Sw pos</i></td> <td><i>Selectivity</i></td> </tr> <tr> <td>2</td> <td>Maximum.</td> </tr> <tr> <td>4KC</td> <td>Medium.</td> </tr> <tr> <td>8</td> <td>Minimum.</td> </tr> </table>	<i>Sw pos</i>	<i>Selectivity</i>	2	Maximum.	4KC	Medium.	8	Minimum.
<i>Sw pos</i>	<i>Selectivity</i>								
2	Maximum.								
4KC	Medium.								
8	Minimum.								
Frequency indicator .....	Indicates receiver operating frequency.								
MEGACYCLES control .....	Selects any one of 32 receiving bands as indicated on the frequency indicator.								
KILOCYCLES control .....	Tunes receiver as indicated on the frequency indicator.								
DIAL ZERO control .....	Calibrates frequency indicator.								
ANT TRIM control .....	Adjusts audio level at the headset by tuning the antenna.								
CARRIER LEVEL meter .....	Indicates strength of signal being received.								
DIAL DIM switch .....	Selects any one of three conditions for the dial lamps: <table border="0"> <tr> <td><i>Sw pos</i></td> <td><i>Condition</i></td> </tr> <tr> <td>OFF</td> <td>Off.</td> </tr> <tr> <td>DIAL DIM</td> <td>Dimly lighted.</td> </tr> <tr> <td>ON</td> <td>Maximum brightness.</td> </tr> </table>	<i>Sw pos</i>	<i>Condition</i>	OFF	Off.	DIAL DIM	Dimly lighted.	ON	Maximum brightness.
<i>Sw pos</i>	<i>Condition</i>								
OFF	Off.								
DIAL DIM	Dimly lighted.								
ON	Maximum brightness.								
DIAL LOCK control .....	Locks the KILOCYCLES control.								

## Section II. OPERATION UNDER USUAL CONDITIONS

### 21. Types of Operation

a. Radio Set AN/GRC-19 may be operated either locally or remotely. When operated locally, voice, radioteletype, or continuous-wave operation is possible. The same facilities are available remotely through the use of auxiliary equipment (Transmitter Control C-822/GRC-19 and Cable Assembly, Special Purpose, Electrical CX-2585/U described in TM 11-806/TO 31R2-2GRC19-11).

b. Radioteletype operation, simplex or du-

plex, requires the use of auxiliary teletypewriter equipment comprised of many different units. Since there are various types of teletypewriter equipment available, no attempt is made here to list these equipments or to provide an operating procedure which would limit the use of Radio Set AN/GRC-19 to any one teletypewriter equipment. Operating procedures involving the use of teletypewriter equipment are given in paragraphs 28 through 32; these procedures are flexible and, there-

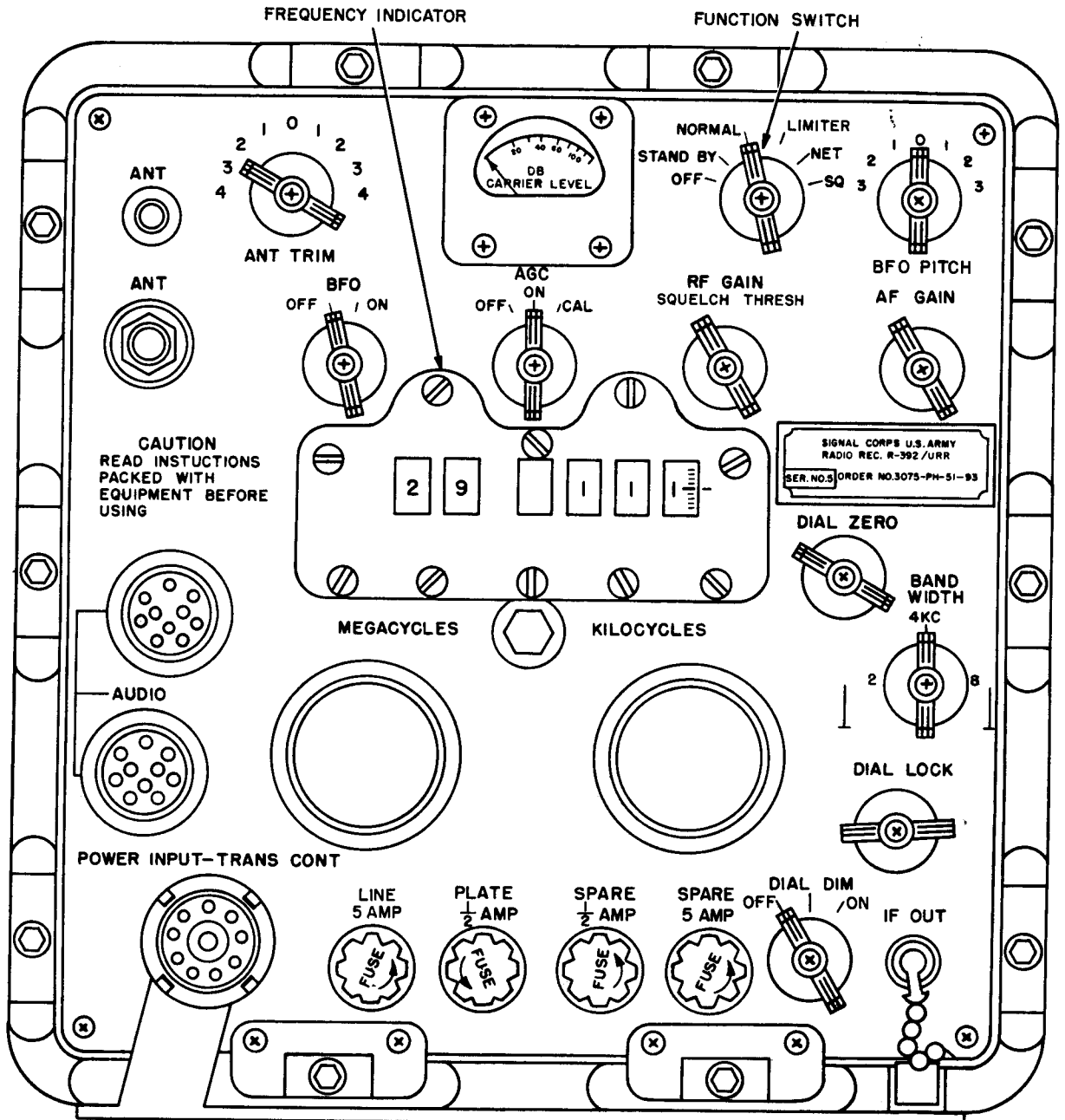

Figure 21. Receiver, Radio R-392/URR, controls and indicators.

fore, apply to all types of teletypewriter equipment. Detailed operating procedures are given only for the controls and indicators of Radio Set AN/GRC-19. Where a step in the procedure requires the operation of teletypewriter equipment, the teletypewriter equipment is referred to in general terms.

c. For FSK operation, additional cable con-

nections will have to be made internally in the transmitter. Higher echelon personnel are required to make these connections.

## 22. Adjustments and Presetting

a. Be sure that the transmitter has been properly adjusted and preset as described in TM 11-806.

b. Be sure that the receiver has been properly adjusted as described in TM 11-858.

### 23. Precautions

Take the following precautions before operating the radio set:

a. Make sure that the transmitter is connected to a dummy antenna or to an antenna. (Refer to TM 11-806.)

b. Make sure that the air-intake and air-exhaust vents of the transmitter are open. To open vents that are sealed, lift up on the spring clips on each side of the vent cover,

remove the vent cover, and replace it in a reversed position.

c. Do not turn the transmitter PRESET CHANNELS switch until the locking bars of the BAND SELECTOR switch and TUNING CONTROL are locked.

d. Set the SERVICE SELECTOR switch set to STAND BY to allow a warmup time of 5 minutes before using the equipment.

### 24. Preliminary Starting Procedure

a. Before operating the equipment, set the front panel controls as follows for voice, CW, FSK, REMOTE and VOICE/FSK operation.

Unit	Control	Position	
Transmitter .....	SERVICE SELECTOR switch .....	OFF.	
	RELAY-NORMAL-DUPLEX switch .....	NORMAL.	
	BAND SELECTOR switch locking bar .....	Locked.	
	TUNING CONTROL locking bar .....	Locked.	
	PRESET CHANNELS switch .....	Set to desired channel.	
	TEST METER switch .....	BATT.	
	LINE LEVEL DBM control .....	-34.	
Receiver .....	Function switch .....	Voice, fsk, or voice/fsk	Cw
		OFF	OFF
	AGC switch .....	ON	OFF
	BAND WIDTH switch .....	8	2
	AF GAIN control .....	Midposition	Midposition
	BFO switch .....	OFF	ON
	RF GAIN SQUELCH THRESH .....	Maximum clockwise	Maximum clockwise
	DIAL DIM switch .....	As required	As required
	ANT TRIM control .....	0	0
	BFO PITCH control .....	0	0
DIAL LOCK control .....	Maximum counter-clockwise	Maximum counter-clockwise	

b. To operate the transmitter with the PRESET CHANNELS switch set to M (manual tuning), perform the following steps after the front panel controls have been set as outlined in a above.

- (1) Set the PRESET CHANNELS switch to M.
- (2) Unlock the BAND SELECTOR switch and TUNING CONTROL locking bars.
- (3) Set the BAND SELECTOR switch to the desired channel and band as indicated on the band-channel indicator.
- (4) Set the TUNING CONTROL to the

desired frequency as indicated on the frequency indicator.

*Note.* Lock the locking bar of the BAND SELECTOR switch and TUNING CONTROL before setting the PRESET CHANNELS switch to any of its preset positions.

### 25. Equipment Operation Chart

The equipment operation chart lists the procedure to set the equipment into operation systematically. The columns in the chart are explained as follows:

a. *Step.* Each step given in the step column is in the proper sequence to prevent the possibility of equipment damage through an im-

proper sequence of operations. In addition, the performance of each step in sequence provides the most efficient means of operating the equipment. Do not vary the sequence.

b. *Unit.* The name of the unit (receiver, transmitter, etc.) to which the step applies is listed in this column.

c. *Control or Indicator.* In this column, all the controls and indicators involved in performing each step are listed in line with the step number.

d. *Action.* All the actions and instructions required to perform a step are given in this column.

## 26. Simplex Voice Operation

Before operating the equipment as shown in the equipment operation charts below, set the front panel controls as outlined in paragraph 24.

### a. Receiving.

Step	Unit	Control or indicator	Action
1	Receiver .....	Function switch .....	Set the function switch to NORMAL.
2	Receiver .....	MEGACYCLES control, ..... KILOCYCLES control.	Turn the MEGACYCLES and KILOCYCLES controls until the desired frequency is indicated on the frequency indicator dial or until the desired signal is received.
3	Receiver .....	CARRIER LEVEL meter, ..... KILOCYCLES control, ANT TRIM control	If the CARRIER LEVEL meter indicates when a signal is being received, first adjust the KILOCYCLES control and then adjust the ANT TRIM control to obtain a maximum (peak) indication on the meter.  If the CARRIER LEVEL meter does not indicate when a signal is being received, first adjust the KILOCYCLES control and then adjust the ANT TRIM control to obtain maximum loudness at the headset.
4	Receiver .....	DIAL LOCK control .....	Lock the KILOCYCLES control by turning the DIAL LOCK to a maximum clockwise position.
5	Receiver .....	AF GAIN control .....	Adjust the AF GAIN control so that the received signal is at a comfortable level at the headset.
6	Receiver .....	Function switch .....	If objectionable static is heard at the headset, set the function switch to LIMITER.
7	Receiver .....	BAND WIDTH switch .....	If interference is caused by another signal when a voice or tone signal is being received, set the BAND WIDTH switch to 4KC or, if necessary, to 2.
8	Receiver .....	Function switch ..... RF GAIN SQUELCH THRESH control.	If the noise heard in the headset is very annoying when no signal is received, set the function switch to SQ and turn the RF GAIN SQUELCH THRESH control slowly counterclockwise to a point which minimizes the noise. Do not set the function switch to SQ if the signal is weak or subject to fading. If it is necessary to move the RF GAIN SQUELCH THRESH control more than a small amount counterclockwise, set the function switch back to its original setting (NORMAL or LIMITER).  If the function switch is set to NORMAL or LIMITER, proceed with step 10 below.  If the function switch remains set at SQ, proceed with step 9 below.

Step	Unit	Control or indicator	Action
9	Receiver .....	RF GAIN SQUELCH THRESH control.	Adjust the RF GAIN SQUELCH THRESH control clockwise so that the received signal at the headset is loud and clear.
10	Receiver .....	AF GAIN control .....	Adjust the AF GAIN control so that the received signal is at a comfortable level at the headset.

*b. Sending.*

Step	Unit	Control or indicator	Action
1	Transmitter ....	SERVICE SELECTOR switch ....	Set the transmitter SERVICE SELECTOR switch to VOICE/FSK.
2	Transmitter ....	DIAL DIM switch, ..... Microphone switch, TUNING INDICATOR, Test meter.	Set the DIAL DIM switch to DIM or FULL. Press the switch on the microphone and hold it closed until the transmitter TUNING INDICATOR lights and the test meter indicates in the shaded area marked PA CATHODE (TUNING INDICATOR should light when tuning cycle is completed).  <i>Note.</i> If the transmitter has been manually tuned from one frequency to another in the same band, the TUNING INDICATOR may not light. In this case, switch the BAND SELECTOR switch to an adjacent band and back again and wait for the tuning cycle to be completed.
3	Transmitter ....	Microphone switch .....	Hold the microphone about 2 inches from the lips. Press the microphone switch and speak in a normal voice. The pointer on the audio level meter should move. Voice peaks should produce an indication of approximately 80 percent.

## 27. Simplex CW Operation

Before operating the equipment as shown in the equipment operation charts below, set

the front panel controls as outlined in paragraph 24.

*a. Receiving.*

Step	Unit	Control or indicator	Action
1	Receiver .....	Function switch .....	Set the function switch to NORMAL.
2	Receiver .....	AGC switch .....	Set the AGC switch to OFF.
3	Receiver .....	BFO switch .....	Set the BFO switch to ON.
4	Receiver .....	DIAL LOCK .....	Unlock the KILOCYCLES control by turning the DIAL LOCK to a maximum counterclockwise position.
5	Receiver .....	MEGACYCLES control, ..... KILOCYCLES control.	Turn the MEGACYCLES and KILOCYCLES controls until the desired frequency is indicated on the frequency indicator dial or until the desired signal is received.
6	Receiver .....	KILOCYCLES control .....	Adjust the KILOCYCLES control to obtain a zero beat at the headset with the desired signal.
7	Receiver .....	DIAL LOCK .....	Lock the KILOCYCLES control by turning the DIAL LOCK to a maximum clockwise position.

Step	Unit	Control or indicator	Action
8	Receiver .....	BAND WIDTH switch .....	Set the BAND WIDTH switch to 2 or 4KC.
9	Receiver .....	BFO PITCH control .....	Adjust the BFO PITCH control to obtain a pleasing tone at the headset.
10	Receiver .....	ANT TRIM control .....	Adjust the ANT TRIM control to obtain maximum loudness of the desired signal at the headset.
11	Receiver .....	RF GAIN SQUELCH THRESH control.	Adjust the RF GAIN SQUELCH THRESH control to obtain a loud and clear signal at the headset.
12	Receiver .....	AF GAIN control .....	Adjust the AF GAIN control so that the received signal is at a comfortable level at the headset.
13	Receiver .....	Function switch .....	If objectionable noise or static is heard at the headset, set the function switch to LIMITER.  <i>Note.</i> Do not set the function switch to SQ for CW operation.

*b. Sending.*

Step	Unit	Control or indicator	Action
1	Transmitter .....	SERVICE SELECTOR switch ....	Set the SERVICE SELECTOR switch to CW.
2	Transmitter .....	DIAL DIM switch ....., TUNING INDICATOR, Test meter, Telegraph key.	Set the DIAL DIM switch to DIM or FULL. Connect the telegraph key to the AUDIO connector. Press the telegraph key and hold it closed until the transmitter TUNING INDICATOR lights and the test meter indicates in the shaded area marked PA CATHODE (TUNING INDICATOR should light when tuning cycle is completed).  <i>Note.</i> If the transmitter has been manually tuned from one frequency to another in the same band, the TUNING INDICATOR may not light. In this case, switch the BAND SELECTOR switch to an adjacent band and back again and wait for the tuning cycle to be completed.
3	Transmitter .....	Telegraph key .....	Operate the telegraph key.

## 28. Simplex FSK Operation

Before operating the equipment as shown in the equipment operation charts below, set the

front panel controls as outlined in paragraph 24.

*a. Receiving.*

Step	Unit	Control or indicator	Action
1	Receiver .....	Function switch .....	Set the function switch to NORMAL.
2	Receiver .....	DIAL LOCK .....	Unlock the KILOCYCLES control by turning the DIAL LOCK to a maximum counterclockwise position.
3	Receiver .....	MEGACYCLES control, ....., KILOCYCLES control.	Turn the MEGACYCLES and KILOCYCLES controls until the desired frequency is indicated on the frequency indicator dial or until the desired signal is received. (Refer to the teletypewriter equipment operating procedures to obtain the required frequency.)



Step	Unit	Control or indicator	Action
4	Receiver .....	DIAL LOCK .....	Lock the KILOCYCLES control by turning the DIAL LOCK to a maximum clockwise position.
5	Receiver .....	BAND WIDTH switch .....	Set the BAND WIDTH switch to 2 or 4KC.
6	Receiver .....	ANT TRIM control .....	Adjust the ANT TRIM control to obtain maximum loudness of the desired signal at the headset.
7	Receiver .....	AF GAIN control .....	Adjust the AF GAIN control so that the received signal is loud enough at the headset.
8	Receiver .....	RF GAIN SQUELCH THRESH control.	Turn the RF GAIN SQUELCH THRESH control to a maximum counterclockwise position. <i>Slowly</i> turn the control clockwise until the teletypewriter starts to type.
9	Receiver .....	Function switch .....	If objectionable noise or static is heard at the headset, set the function switch to LIMITER.

*b. Sending.*

Step	Unit	Control or indicator	Action
1	Transmitter .....	SERVICE SELECTOR switch ....	Set the SERVICE SELECTOR switch to VOICE/FSK.
2	Teletypewriter..	Transmitter on-off switch .....	Refer to the teletypewriter equipment operating procedures.
3	Transmitter .....	DIAL DIM switch, ..... TUNING INDICATOR, Test meter.	Set the DIAL DIM switch to DIM or FULL. The transmitter tuning indicator should light and the test meter should indicate in the shaded area marked PA CATHODE (TUNING INDICATOR should light when tuning cycle is completed). <i>Note.</i> If the transmitter has been manually tuned from one frequency to another in the same band, the TUNING INDICATOR may not light. In this case, switch the BAND SELECTOR switch to an adjacent band and back again and wait for the tuning cycle to be completed.
4	Teletypewriter..		Operate the teletypewriter equipment. <i>Note.</i> Simultaneous reception and transmission is not possible.

## 29. Simplex VOICE/FSK Operation

Before operating the equipment as shown in the equipment operation charts below, set the

*a. Receiving.*

front panel controls as outlined in paragraph 24.

Step	Unit	Control or indicator	Action
1	Receiver .....	Function switch .....	Set the function switch to NORMAL.
2	Receiver .....	DIAL LOCK .....	Unlock the KILOCYCLES control by turning the DIAL LOCK to a maximum counterclockwise position.
3	Receiver .....	MEGACYCLES control, ..... KILOCYCLES control.	Turn the MEGACYCLES and KILOCYCLES controls until the desired frequency is indicated on the frequency indicator dial or until the desired signal is received. (Refer to the teletypewriter equipment operating procedures to obtain the required frequency.)

Step	Unit	Control or indicator	Action
4	Receiver .....	DIAL LOCK .....	Lock the KILOCYCLES control by turning the DIAL LOCK to a maximum clockwise position.
5	Receiver .....	BAND WIDTH switch .....	Set the BAND WIDTH switch to 2 or 4KC.
6	Receiver .....	ANT TRIM control .....	Adjust the ANT TRIM control to obtain maximum loudness of the desired signal at the headset.
7	Receiver .....	RF GAIN SQUELCH THRESH control.	Turn the RF GAIN SQUELCH THRESH control to a maximum counterclockwise position. <i>Slowly</i> turn the control clockwise until the teletypewriter starts to type.
8	Receiver .....	Function switch .....	If objectionable noise or static is heard at the headset, set the function switch to LIMITER.

*b. Sending.*

Step	Unit	Control or indicator	Action
1	Transmitter .....	SERVICE SELECTOR switch ....	Set the SERVICE SELECTOR switch to VOICE/FSK.
2	Teletypewriter..	Transmitter on-off switch .....	Refer to the teletypewriter equipment operating procedures.
3	Transmitter .....	DIAL DIM switch, .....	Set the DIAL DIM switch to DIM or FULL. The transmitter TUNING INDICATOR will light and the test meter should indicate in the shaded area marked PA CATHODE (TUNING INDICATOR should light when tuning cycle is completed). <i>Note.</i> If the transmitter has been manually tuned from one frequency to another in the same band, the TUNING INDICATOR may not light. In this case, switch the BAND SELECTOR switch to an adjacent band and back again and wait for the tuning cycle to be completed.
		TUNING INDICATOR, Test meter.	
4	Transmitter and teletypewriter.		Operate the teletypewriter equipment. At the same time, hold the microphone about 2 inches from the lips. Press the microphone switch and speak in a normal voice. Speak so that the audio level meter will indicate close to 100 but not over 100.

### 30. Duplex Operation

Set the transmitter RELAY-NORMAL-DUPLEX switch to DUPLEX and operate the equipment in accordance with the instructions for voice (par. 26), for CW (par. 27), for FSK (par. 28), or for VOICE/FSK (par. 29).

*Note.* For duplex operation, disconnect Cable Assembly, Radio Frequency CG-1127/U from the transmitter RECEIVER ANTENNA connector and from the receiver ANT connector. Connect an additional antenna (Antenna Group AN/GRA-12 or whip antenna) to the receiver ANT connector.

### 31. Relay Operation

*Note.* For relay operation, disconnect Cable Assembly, Radio Frequency CG-1127/U from the transmitter RECEIVER ANTENNA connector and from the receiver ANT connector. Connect an additional antenna

(Antenna Group AN/GRA-12 or whip antenna) to the receiver ANT connector.

*a. Voice (receiving).* Operate the receiver as outlined in paragraph 26a, steps 1 through 10. In addition, adjust the transmitter LINE LEVEL DBM control to give an indication close to 100, but not over 100, on the transmitter audio level meter. If the audio level meter cannot be made to indicate close to 100 when LINE LEVEL DBM control is adjusted, turn the receiver AF GAIN control approximately 1/4-turn clockwise and readjust the LINE LEVEL DBM control.

*b. Voice (sending).* Operate the transmitter as shown in the equipment operation chart below:

Step	Unit	Control or indicator	Action
1	Transmitter .....	RELAY-NORMAL-DUPLEX switch.	Set the RELAY-NORMAL-DUPLEX switch to RELAY.
2	Transmitter .....	SERVICE SELECTOR switch ....	Set the transmitter SERVICE SELECTOR switch to VOICE/FSK.
3	Transmitter .....	DIAL DIM switch, .....  TEST KEY switch,  TUNING INDICATOR,  Test meter.	Set the DIAL DIM switch to DIM or FULL.  Set the TEST KEY switch to ON and hold it at the ON position until the transmitter TUNING INDICATOR lights and the test meter indicates in the shaded area marked PA CATHODE (TUNING INDICATOR should light when tuning cycle is completed).  <i>Note.</i> If the transmitter has been manually tuned from one frequency to another in the same band, the TUNING INDICATOR may not light. In this case, switch the BAND SELECTOR switch to an adjacent band and back again and wait for the tuning cycle to be completed.

c. *CW (receiving)*. Operate the receiver as indicated in the steps outlined in paragraph 27a.

d. *CW (sending)*. Operate the transmitter as follows:

Step	Unit	Control or indicator	Action
1	Transmitter .....	RELAY-NORMAL-DUPLEX switch.	Set the RELAY-NORMAL-DUPLEX switch to RELAY.
2	Transmitter .....	SERVICE SELECTOR switch ....	Set the SERVICE SELECTOR switch to CW.
3	Transmitter .....	DIAL DIM switch, .....  TEST KEY switch,  TUNING INDICATOR,  Test meter.	Set the DIAL DIM switch to DIM or FULL.  Set the TEST KEY switch to ON and hold it at the ON position until the transmitter TUNING INDICATOR lights and the test meter indicates in the shaded area marked PA CATHODE (TUNING INDICATOR should light when tuning cycle is completed).  <i>Note.</i> If the transmitter has been manually tuned from one frequency to another in the same band, the TUNING INDICATOR may not light. In this case, switch the BAND SELECTOR switch to an adjacent band and back again and wait for the tuning cycle to be completed.

e. *FSK*. Operate the equipment in accordance with the instructions outlined in paragraph 28a and steps 1 through 3 in paragraph 28b.

*Note.* Relay FSK operation is not usually used.

f. *VOICE/FSK*. Operate the equipment in accordance with the instructions outlined in paragraph 29a and steps 1 through 3 in paragraph 29b.

*Note.* Relay VOICE/FSK operation is not usually used.

## 32. REMOTE Operation

The transmitter may be remotely controlled

from a distance up to 75 feet through the use of Transmitter Control C-822/GRC-19 and Cable Assembly, Special Purpose, Electrical CX-2585/U (auxiliary equipment). The type of operation, OFF, CW, STAND BY, or FSK/VOICE can be selected by the SERVICE SELECTOR switch of Transmitter Control C-822/GRC-19. In addition, Transmitter Control C-822/GRC-19 contains a PRESET CHANNELS switch, that selects any one of seven preset transmitter channels, and a TUNING INDICATOR lamp that indicates the condition of the transmitter automatic tuning

cycle. For remote operation of the transmitter by Transmitter Control C-822/GRC-19, refer to paragraph 40.

### 33. Recognition and Identification of Jamming

Under real or simulated tactical conditions, the receiver will likely be jammed by the enemy. Enemy jamming is easily done by transmitting a strong signal on the same frequency and thereby making it difficult or impossible to hear the desired signal. Unusual noises or strong interference heard on the receiver may be enemy jamming, signals from a friendly station, noise from a local source, or may indicate that the receiver is defective. To determine whether the interference is originating in the receiver, disconnect the antenna, remove the antenna, or short the antenna post to the chassis. If the interference *continues*, the receiver is defective. Enemy jamming signals may be typed as *continuous wave* or *modulated*. A jamming signal intended to block a single frequency, is called *spot* jamming. The enemy may use one or several transmitters to jam a block or band of frequencies; this method is called *barrage* jamming.

a. *Continuous-Wave Jamming*. Cw jamming is transmitted as a steady carrier. This signal beats with another signal and produces a steady tone in the headset. Cw jamming signals may also be keyed by using a random on and off signal or using actual code characters keyed at the same rate or a little faster than the signal being received.

b. *Modulated Jamming*. Modulated jamming signals may consist of noise, laughter, singing, music, various tones, or unusual sound, or it may be a combination of these sounds. Various types of modulated jamming signals are explained below.

(1) *Spark*. This is one of the simplest, most effective, and most easily produced jamming signal. This type of signal sounds very rough, raspy, and sometimes like an electric motor with sparking brushes running. This type of signal is very broad; therefore, it will interfere with a large number of communication channels.

(2) *Sweepthrough*. This signal is the result of sweeping or moving a carrier

back and forth across your frequency at a slow or rapid rate. The numerous signals of varying amplitude and frequency produce a sound like that of a low-flying airplane passing overhead. This type of jamming is effective over a broad range of frequencies. When it is varied rapidly, it is effective against all types of voice signals.

(3) *Stepped tones or bagpipes*. This signal usually consists of several separate tones. The tones are transmitted in the order of first increasing and then decreasing pitch, repeated over and over. The audible effect is like the sound of a Scottish bagpipe.

(4) *Noise*. Noise is random both in amplitude and frequency. It is considered one of the better types of jamming modulation. It produces a sound similar to that heard when a receiver is not tuned to a station and the volume or gain control is turned to maximum.

(5) *Gulls*. This signal consists of a quick rise and slow fall of a variable audio-frequency. The sound is similar to the cry of the sea gull.

(6) *Tone*. This signal consists of a single audiofrequency of unvarying tone. It produces a steady howl in the headset. When varied slowly, it produces a howling sound of varying pitch.

### 34. Antijamming

When it is known that a receiver is being jammed, the operator will notify the immediate superior officer immediately and continue to operate the equipment. To provide maximum intelligibility of jammed signals, follow the operational procedure below:

a. Set the BAND WIDTH switch to 2.

b. Detune the receiver by turning the KILOCYCLES control several degrees on either side of the desired signal. Detuning may cause some separation of the desired signal and the jamming signal.

c. Adjust the ANT TRIM control. This adjustment may reduce the strength of the jamming signal.

d. If voice signals are being received, set the AGC switch to OFF. If cw signals are being received, the AGC switch is already set

to OFF. Vary the RF GAIN SQUELCH THRESH control. Varying this control may reduce the jamming signal enough to permit the desired weaker signal to be heard.

e. If cw signals are being received, adjust the BFO PITCH control. This adjustment may reduce the jamming signal enough to permit the wanted signal to be heard.

f. If the above procedures do not provide sufficient signal separation for operation, proceed as follows:

- (1) If the radio set is installed in a vehicle, move the vehicle (if possible) to a new location.
- (2) If a doublet antenna (Antenna Group AN/GRA-12; auxiliary equipment) is being used, change the location (if possible) of the antenna. If the jam-

ming signal still does not permit operation, change to a whip antenna.

- (3) If a whip antenna is being used, change to a doublet antenna.
- (4) Change to an alternate frequency and alternate call sign.

### **35. Stopping Procedure**

a. *Stopping Equipment.*

- (1) Set the transmitter SERVICE SELECTOR switch to OFF.
- (2) Set the receiver function switch to OFF.

b. *Standby Condition.*

- (1) Set the transmitter SERVICE SELECTOR switch to STAND BY.
- (2) Set the receiver function switch to STAND BY.

ADDITIONAL ITEMS FOR 2D AND 3D ECHELON INSPECTIONS  26. <del>INSPECT ANTENNA FOR ECCENTRICITIES, CORROSION, LOOSE FIT, DAMAGED INSULATOR AND REFLECTORS.</del>  27. <del>CHECK FOR NORMAL OPERATION.</del>  28. <del>BEFORE SHARING OR STORING, REMOVE BATTERIES.</del>	CONDITION	<b>MAINTENANCE CHECK LIST FOR SIGNAL EQUIPMENT</b> SOUND EQUIPMENT, RADIO, DIRECTION FINDING RADAR, CARRIER, RADIOSONDE AND TELEVISION (AR 750-625)	EQUIPMENT NOMENCLATURE <i>Radio Set AN/CRC-19</i>	EQUIPMENT SERIAL NUMBER 0000	<p style="text-align: center;"><b>INSTRUCTIONS</b></p> <p>This form may be used for a period of one month by using the correct dates and weeks of the month. It is to be used as a Preventive Maintenance check list for Signal equipment in actual use, or for a check on equipment prior to issue.</p> <p>1. For detailed Preventive Maintenance instructions see:                  a. The Technical Manual (in TM 11 series) for the equipment.                  (See DA Pamphlet Number 310-4)                  b. The Supply Bulletin (SB 11-100 series) for the equipment.                  (See DA Pamphlet Number 310-4)                  c. The Department of the Army Lubrication Order.                  (See DA Pamphlet Number 310-4)</p> <p>2. The following action will be taken by either the Communications Officer/Chief for 1st echelon, or the Inspector for higher echelon:                  a. Enter Equipment Nomenclature and Serial Number.                  b. Strike out items that do not apply to the equipment.</p> <p>3. Operator/Inspector will enter in the columns entitled <b>CONDITION</b>, on the proper line, a notation regarding the condition, using symbols specified under <b>LEGEND</b>.</p> <p>4. After operator completes each daily inspection he will initial over the appropriate dates under "Daily Condition for Month", then return form to his supervisor.</p>
IF DEFICIENCIES NOTED ARE NOT CORRECTED DURING THE INSPECTION, INDICATE ACTION TAKEN FOR CORRECTION.					TYPE OF INSPECTION
		OPERATOR	DATE	SIGNATURE	
		✓	7 Dec 1959	<i>John Jones</i>	

REPLACES DA FORMS 11-236, 11 NOV 55; 11-239, 11-244, 11-245, 11-246, 11-249, 11-250, AND 11-251; WHICH ARE OBSOLETE.

**DA FORM 11-238**

Figure 22. DA Form 11-238, pages 1 and 4.

## CHAPTER 4

### MAINTENANCE INSTRUCTIONS

#### 36. Scope of Operator's Maintenance

The following is a list of maintenance duties normally performed by the operator of Radio Set AN/GRC-19. These procedures do not require special tools or test equipment.

- a. Preventive maintenance (par. 37).
- b. Checking cable connections (par. 17).
- c. Visual inspection (par. 38).

#### 37. Preventive Maintenance

a. *DA Form 11-238.* DA Form 11-238 (figs. 22 and 23) is a preventive maintenance checklist to be used by the operator. Items not applicable to the operator of the radio set are lined out in the figures. References in the ITEM block in the figures are to paragraphs that contain additional maintenance information pertinent to the particular item. Instructions for the use of the form appear on the form.

b. *Items.* The information shown in the chart below is supplementary to DA Form 11-238. The item numbers correspond to the ITEM numbers on the form.

Item	Maintenance procedures
2	Use a clean cloth to remove dust, dirt, moisture, and grease from the antenna, mast base, microphone, headset, and front panel controls. If necessary, wet the cloth with

Item	Maintenance procedures
	cleaning compound and then wipe the parts with a dry clean cloth.
3	All control knobs should work smoothly, be tight on the shaft, and should not bind.
6	Remove rust from components and touch up bare spots with paint.
7	Repair any cuts in the insulation by covering them with rubber tape and then with friction tape. Replace all broken cords and cables.

**Warning:** Cleaning compound is flammable and its fumes are toxic. Do not use near a flame and provide adequate ventilation.

#### 38. Visual Inspection

When the equipment fails to perform properly, turn off the power and check all the items listed below. *Do not check any item with the power on.*

- a. Wrong setting of switches and controls (par. 18 through 20).
- b. Cables, headset cord, or antenna lead-in wire poorly connected (par. 17).
- c. Disconnected cables, plugs, or headset cord.
- d. Grounded or broken antenna or antenna lead-in wire.

LEGEND for marking conditions: Satisfactory, Y. Adjustment, Repair or Replacement required, X. Defect corrected, (X).		DAILY CONDITION FOR MONTH OF <i>December 1959</i>															
		1	2	3	4	5	6	7	8	9	10	11	12	13	14	15	16
NO.	DAILY ITEM	17	18	19	20	21	22	23	24	25	26	27	28	29	30	31	
	1. COMPLETENESS AND GENERAL CONDITION OF EQUIPMENT. (Transmitter, receiver, carrying cases, wire, cables, microphones, tubes, spare parts, technical manuals).	/	/	/	/	/	/	/	/	/	/	/	/	/	/	/	
	2. CLEAN DIRT AND MOISTURE FROM ANTENNA, MICRO-PHONES, HEADSETS, KEYS, JACKS, PLUGS, COMPONENT PANELS.	/	/	/	/	/	/	/	/	/	/	/	/	/	/	/	
	3. INSPECT CONTROLS FOR NORMAL OPERATION. TAP CONTROLS LIGHTLY FOR EVIDENCE OF CUT-OUT FROM LOOSE CONTACTS.	/	/	/	/	/	/	/	/	/	/	/	/	/	/	/	
	4. CHECK FOR NORMAL OPERATION OF EQUIPMENT. BE ALERT FOR UNUSUAL OPERATION OR CONDITION.	/	/	/	/	/	/	/	/	/	/	/	/	/	/	/	
	5. CLEAN AND TIGHTEN EXTERIORS OF CASES, RACKS, MOUNTS, TRANSMISSION LINES.	/	/	/	/	/	/	/	/	/	/	/	/	/	/	/	
	6. INSPECT CASES, MOUNTS, ANTS-NNNA TOWERS AND EXPOSED METAL SURFACES FOR RUST, CORROSION.	/	/	/	/	/	/	/	/	/	/	/	/	/	/	/	
	7. INSPECT CORDS, CABLE, WIRE, SHOCK MOUNTS FOR CUTS, KINKS, BREAKS, FRAYING, UNDUE STRAIN.	/	/	/	/	/	/	/	/	/	/	/	/	/	/	/	
	8. CHECK ANTENNA GUY WIRES FOR PROPER TENSION OR DAMAGE.	/	/	/	/	/	/	/	/	/	/	/	/	/	/	/	
	9. INSPECT CANVAS AND LEATHER ITEMS FOR MILDEW, TEARS, FRAYING.	/	/	/	/	/	/	/	/	/	/	/	/	/	/	/	
	10. INSPECT ACCESSIBLE ITEMS FOR LOOSE NUTS, SWITCHES, KNOBS, JACKS, CONNECTORS, LIGHTS, BATTERIES, WORN OR LOOSE PARTS.	/	/	/	/	/	/	/	/	/	/	/	/	/	/	/	
	11. CLEAN AND/OR INSPECT AIR FILTERS, BRASS NAME PLATES, DIAL AND METER WINDOWS.	/	/	/	/	/	/	/	/	/	/	/	/	/	/	/	
	12. INSPECT STORAGE BATTERIES FOR DIRT, LOOSE TERMINALS, SPECIFIC GRAVITY DAMAGES, CHECK INSPECT DRY BATTERIES FOR LEAKAGE.	/	/	/	/	/	/	/	/	/	/	/	/	/	/	/	
	13. INSPECT SHELTERS AND COVERS FOR ADEQUACY OF WEATHER PROOFING, TEARS, FRAYING.	/	/	/	/	/	/	/	/	/	/	/	/	/	/	/	
	14. CHECK TERMINAL BOX COVERS FOR CRACKS, DIRT, LEAKS, DAMAGED GASKETS, GROUNDING.	/	/	/	/	/	/	/	/	/	/	/	/	/	/	/	
	15. CHECK TERMINAL BOX COVERS FOR CRACKS, DIRT, LEAKS, DAMAGED GASKETS, GROUNDING.	/	/	/	/	/	/	/	/	/	/	/	/	/	/	/	
	16. INSPECT RELAYS AND CIRCUIT BREAKERS FOR LOOSE MOUNTINGS, BAD CONTACTS, MIS-ALIGNMENT OF CONTACTS AND SPRINGS, PROPER SPRING TENSION.	/	/	/	/	/	/	/	/	/	/	/	/	/	/	/	
	17. INSPECT VARIABLE CAPACITORS FOR DIRT, MIS-ALIGNMENT OF PLATES, LOOSE MOUNTINGS, MOISTURE.	/	/	/	/	/	/	/	/	/	/	/	/	/	/	/	
	18. INSPECT RESISTORS, BUSHINGS AND INSULATORS FOR CRACKS, CHIPPING, DISCOLORING, MOISTURE, DISCOLORATION.	/	/	/	/	/	/	/	/	/	/	/	/	/	/	/	
	19. CLEAN AND TIGHTEN SWITCHES, TERMINAL DECKS, SWITCHES, RELAY SWITCHES AND INTERLOCKS OF CHANGES AND SWITCHES NOT READILY ACCESSIBLE.	/	/	/	/	/	/	/	/	/	/	/	/	/	/	/	
	20. INSPECT TERMINAL BOXES FOR LOOSE CONNECTIONS, CRACKS AND BREAKS.	/	/	/	/	/	/	/	/	/	/	/	/	/	/	/	
	21. INSPECT TERMINALS OF LARGE FIXED CAPACITORS AND RESISTORS FOR DIRT, CORROSION, LOOSE CONTACTS.	/	/	/	/	/	/	/	/	/	/	/	/	/	/	/	
	22. INSPECT TRANSFORMERS, CHOKES, POTENTIOMETERS AND RHEOSTATS FOR OVERHEATING AND OIL LEAKAGE.	/	/	/	/	/	/	/	/	/	/	/	/	/	/	/	
	23. INSPECT GENERATORS, IMPEDANCES, DIAPHRAGMS FOR BRUSH WEAR, BRUSH SPRING TENSION, ARCS AND FITTING OF COMMUTATOR.	/	/	/	/	/	/	/	/	/	/	/	/	/	/	/	
	24. INSPECT BATTERIES FOR PROPER CHARGING, LEAKS, CORROSION, WEAR, DAMAGE TO CASES.	/	/	/	/	/	/	/	/	/	/	/	/	/	/	/	
	25. INSPECT WATERPROOF GASKETS FOR LEAKS, WORN OR LOOSE PARTS.	/	/	/	/	/	/	/	/	/	/	/	/	/	/	/	

CONTINUED ON PAGE 4



## CHAPTER 5

### AUXILIARY EQUIPMENT

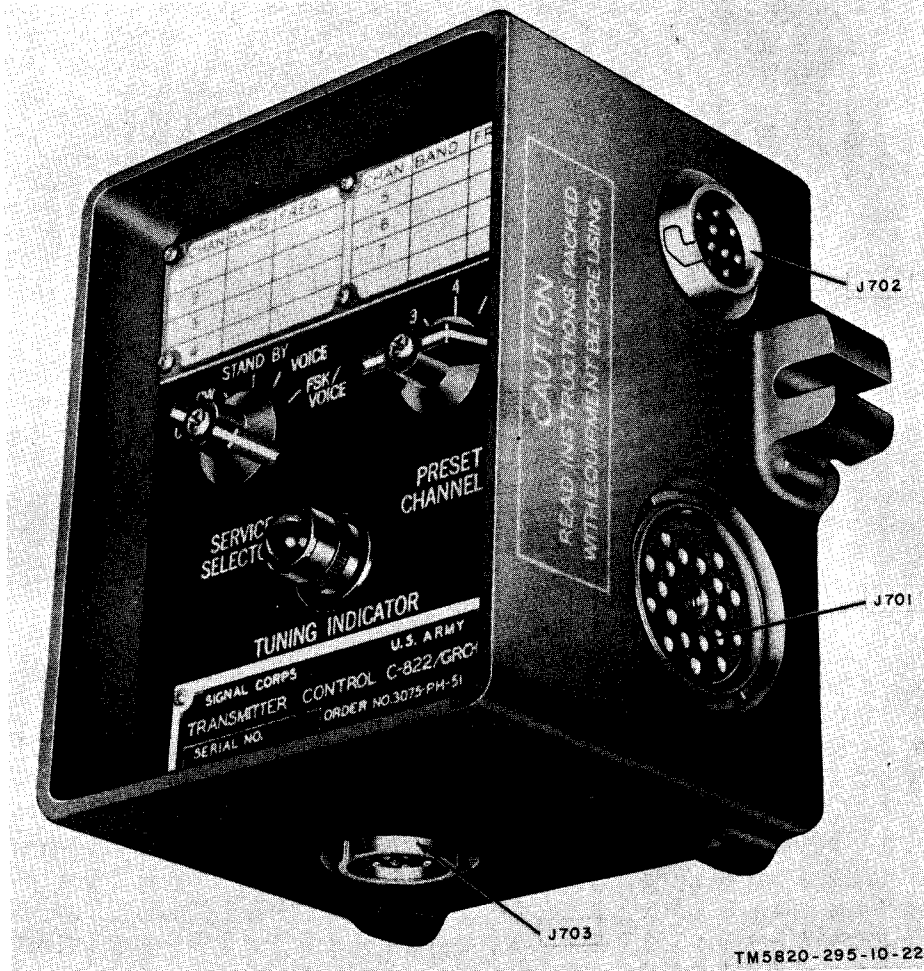

Figure 24. Transmitter Control C-822/GRC-19.

#### 39. Purpose of Auxiliary Equipment

a. Although it is possible to operate Radio Set AN/GRC-19 locally, it may be necessary to install the radio set at one location and to control the operation of Transmitter, Radio T-195 (\*)/GRC-19 from a more protected and remote location. Transmitter Control C-822/GRC-19 (fig. 24) together with Cable Assembly, Special Purpose, Electrical CX-2585/U (fig. 25) may be used for such remote-control operation.

b. Antenna Group AN/GRA-12 (fig. 26) may be used with Radio Set AN/GRC-19 to extend the range of the radio set. For detailed

instructions concerning the AN/GRA-12, refer to TM 11-2651.

#### 40. REMOTE Operation

For REMOTE operation, one end of Cable Assembly, Special Purpose, Electrical CX-2585/U (auxiliary equipment) must be connected to the transmitter REMOTE CONT connector and the other end to connector J701 of Transmitter Control C-822/GRC-19 (auxiliary equipment) (fig. 24). These connections are to be performed only after performing initial operation of the receiver and transmitter as

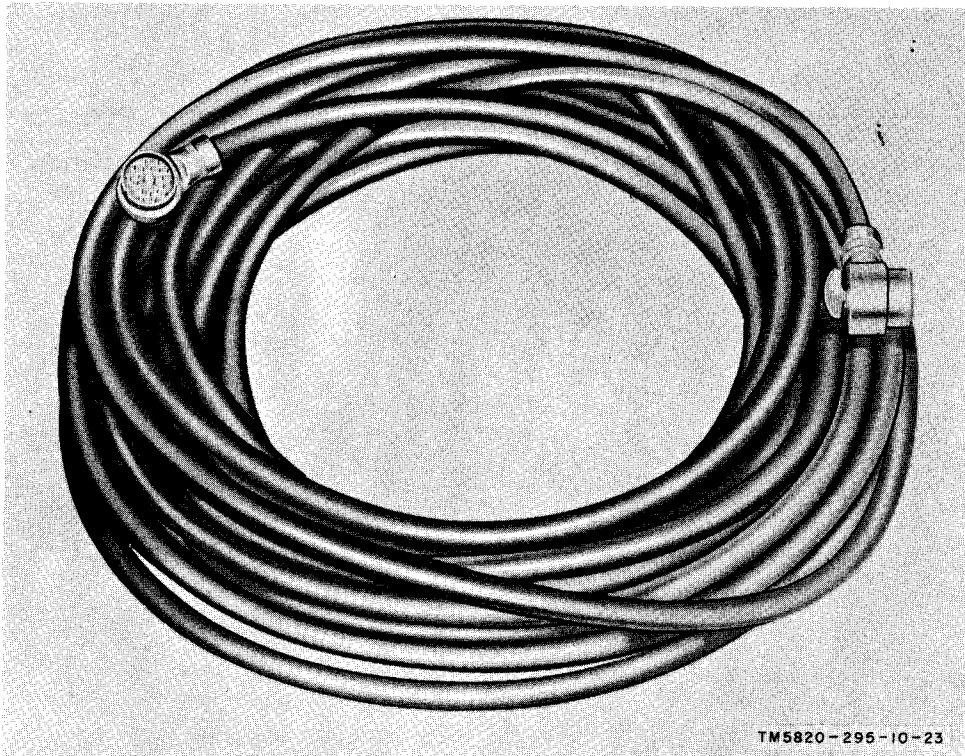

Figure 25. Cable Assembly, Special Purpose, Electrical CX-2585/U.

outlined below. Key, Telegraph KY-116/U; Microphone M-29/U; Headset, Electrical (Navy type 49507A); or frequency-shift keyed equipment must be connected to connector J702 or J703 of Transmitter Control C-822/GRC-19. Only remote control of the transmitter is possible from Transmitter Control C-822/GRC-19. The type of operation, OFF, = CW, STAND BY, or FSK/VOICE can be selected by the SERVICE SELECTOR switch of Transmitter Control C-822/GRC-19. In addition, Transmitter Control C-822/GRC-19 contains a PRESET CHANNELS switch that selects any one of seven preset transmitter channels, and a TUNING INDICATOR lamp that indicates the condition of the transmitter automatic tuning cycle. Reception from the receiver is applied to Headset, Electrical (Navy type 49507A) through connector J702 or J703. Before the transmitter can be operated from a remote point, the transmitter must be initially operated as outlined in the transmitter operating instructions (par. 26 or 27). The receiver must be initially operated, for the type of operation selected, each time the type of operation is

changed from CW to FSK/VOICE, FSK, or voice; from voice to FSK, FSK/VOICE, or CW; and from FSK, FSK/VOICE or CW to voice. After the receiver and transmitter have been initially operated, set the transmitter SERVICE SELECTOR switch to REMOTE and operate Transmitter Control C-822/GRC-19 as follows:

a. *Simplex Voice Operation.*

- (1) Set the SERVICE SELECTOR switch to FSK/VOICE.
- (2) Set the PRESET CHANNELS switch to the desired channel.
- (3) Hold the microphone about 2 inches from the lips. Press the microphone switch and speak in a normal voice.

b. *Simplex CW Operation.*

- (1) Set the SERVICE SELECTOR switch to CW.
- (2) Set the PRESET CHANNELS switch to the desired channel.
- (3) Operate the telegraph key.

c. *Simplex FSK Operation.*

- (1) Set the SERVICE SELECTOR switch to FSK/VOICE.

- (2) Set the PRESET CHANNELS switch to the desired channel.
  - (3) Operate the teletypewriter equipment.
- d. *Simplex VOICE/FSK Operation.*
- (1) Set the SERVICE SELECTOR switch to FSK/VOICE.
  - (2) Set the PRESET CHANNELS switch to the desired channel.
  - (3) Operate the teletypewriter equipment.

At the same time, hold the microphone about 2 inches from the lips. Press the microphone switch and speak in a normal voice.

e. *Duplex Operation.* Refer to paragraph 30 and operate Transmitter Control C-822/GRC-19 in accordance with the instructions for voice (a above), CW (b above), FSK (c above), or for VOICE/FSK (d above).

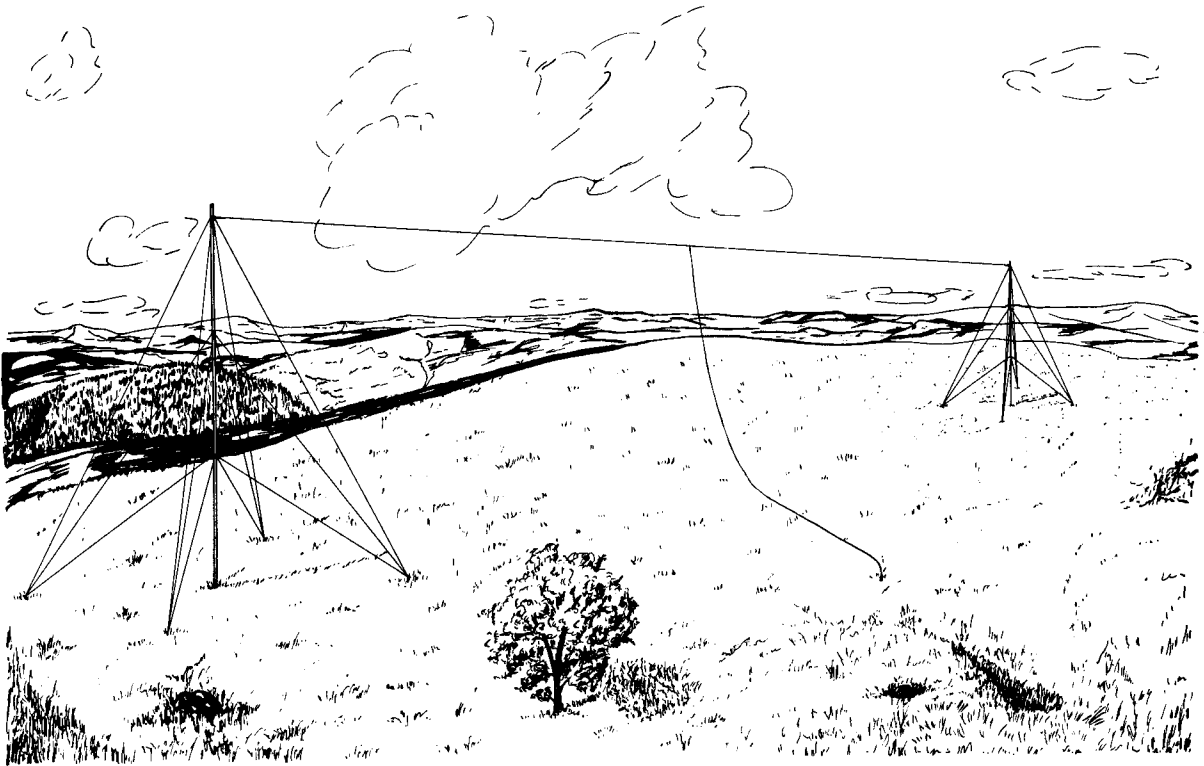

TM5820-295-10-24

Figure 26. Antenna Group AN/GRA-12.

## CHAPTER 6

### SHIPMENT AND LIMITED STORAGE AND DEMOLITION TO PREVENT ENEMY USE

---

#### Section I. SHIPMENT AND LIMITED STORAGE

##### 41. Disassembly of Equipment

Disassembly procedures for Radio Set AN/GRC-19 consist of the following steps:

a. Disconnect Cable Assembly, Power, Electrical CX-2583/U from the 28-volt supply and from the transmitter 24 VOLTS DC connector.

b. Disconnect the telegraph key, or microphone, from the transmitter AUDIO connector.

c. Disconnect Cable Assembly, Special Purpose, Electrical CX-1599/U between the receiver POWER INPUT-TRANS CONT connector and the transmitter RECEIVER CONT connector.

d. Disconnect the headset from the receiver AUDIO connector.

e. Disconnect Cable Assembly, Radio Frequency CG-1127/U between the receiver ANT connector and the transmitter RECEIVER ANTENNA connector.

f. Disconnect the wire between the whip antenna and the transmitter WHIP ANTENNA connector. If an antenna group is connected to the transmitter, disconnect the wire to the transmitter 50 OHMS OUTPUT connector on the transmitter.

g. If teletypewriter equipment is connected to the radio set, disconnect the cables between the teletypewriter equipment and the receiver IF OUT connector, also the cables connected to the FSK IN, and MO OUT connector on the transmitter.

h. If Transmitter Control C-822/GRC-19 is connected to the transmitter, disconnect Cable Assembly, Special Purpose, Electrical CX-2585/U from the REMOTE CONT connector on the transmitter.

i. Disassemble the whip antenna.

j. Loosen the three pressure adjustable clamps at the bottom of the transmitter front panel. Remove the transmitter by grasping the handles on both sides of the front panel and pulling outward and upward.

k. Loosen the two pressure adjustable clamps at the bottom of the receiver front panel. Remove the receiver by grasping the handles on both sides and pulling outward and upward.

##### 42. Repackaging for Shipment or Limited Storage

Repackaging of Radio Set AN/GRC-19 is performed at a higher echelon.

#### Section II. DEMOLITION OF MATERIEL TO PREVENT ENEMY USE

##### 43. Authority for Demolition

Demolition of the equipment will be accomplished only upon the order of the commander. The destruction procedures outlined in paragraph 44 will be used to prevent further use of the equipment.

##### 44. Methods of Destruction

Use any of the following methods to destroy the equipment:

a. *Smash.* Smash the controls, tubes, coils, switches, capacitors, transformers, and meter; use sledges, axes, handaxes, pickaxes, hammers, or crowbars.

b. *Cut.* Cut the output and power cord and slash the rf shield; use axes, handaxes, or machetes.

c. *Burn.* Burn cords and technical manuals; use gasoline, kerosene, oil, flamethrowers, or incendiary grenades.

d. *Bend.* Bend panel and cabinet.

e. *Explode.* If explosives are necessary, use firearms, grenades, or TNT.

f. *Dispose.* Bury or scatter the destroyed parts in slit trenches or foxholes, or throw them into streams.

## APPENDIX I

### REFERENCES

---

Following is a list of applicable references available to the operator of Radio Set AN/GRC-19:

- |            |   |
|------------|---|
| TM 11-806  | Radio Transmitters<br>T-195/GRC-19 and<br>T-195A/GRC-19 |
| TM 11-858  | Radio Receiver R-392/URR                                |
| TM 11-2651 | Antenna Groups AN/GRA-4<br>and AN/GRA-12                |

## APPENDIX II.

### REPAIR PARTS AND SPECIAL TOOLS LIST

---

#### Section I. INTRODUCTION

##### 1. Scope

a. This appendix lists items supplied for initial operation and for running spares. The list includes tools, accessories, parts, and material issued as *part of* the major end item. The list includes all items authorized for basic operator maintenance of the equipment. End items of equipment are issued on the basis of allowances prescribed in equipment authorization tables and other documents that are a basis for requisitioning.

b. The columns are as follows:

- (1) *Source, maintenance, and recoverability code.* Not used.
- (2) *Federal stock number.* This column lists the 11-digit Federal stock number.
- (3) *Designation by model.* Not used.
- (4) *Description.* Nomenclature or the standard item name and brief identifying data for each item are listed in this column. When requisitioning, enter the nomenclature and description on the requisition.
- (5) *Unit of issue.* The unit of issue is the supply term by which the individual item is counted for procurement, storage, requisitioning, allowances, and issue purposes.
- (6) *Expendability.* Expendable items are indicated by the letter X; nonexpendable items are indicated by NX.
- (7) *Quantity authorized.* Under "Items

Comprising an Operable Equipment," the column lists the quantity of items supplied for the initial operation of the equipment. Under "Running Spares and Accessory Items," the quantities listed are those issued initially with the equipment as spare parts. The quantities are authorized to be kept on hand by the operator for maintenance of the equipment.

- (8) *Illustration.* The "Figure No" column lists the figure numbers of the illustrations.

##### 2. Critical Items

A zero slash (Ø) in the "Description" column indicates items that are expected to fail during the first year, and also items that will make the equipment inoperative if they fail.

##### 3. References

A maintenance allocation chart showing all repair operations authorized to be performed by the respective echelons of maintenance is contained in Part II, Organizational Maintenance. Additional instructions concerning maintenance of this equipment are contained in:

SIG 7 & 8 MP-65, Mast Base MP-65; MP-65-A, B, C.

SIG 7 & 8 M-29/U, Microphone, M-29/U; M-29A/U.

TM 11-5820-334-10P, Operator Maintenance Repair Parts and Special Tools List: Receiver, Radio R-392/URR.

## Section II. FUNCTIONAL PARTS LIST

(1) SOURCE MAINTENANCE AND RECOVERABILITY CODE	(2) FEDERAL STOCK NUMBER	(3) DESIGNATION BY MODEL	(4) DESCRIPTION	(5) UNIT OF ISSUE	(6) EXPERIABILITY	(7) QUANTITY AUTHORIZED	(8) ILLUSTRATIONS		(9)
							FIGURE NO.	ITEM NO.	
			ITEMS COMPRISING AN OPERABLE EQUIPMENT RADIO SET AN/GRC-19						
	5820-030-0155		RADIO SET AN/GRC-19	ea	NX	1	1		
	5820-571-1828		Ø ANTENNA, SHEATH CLAMP: Collins part/dwg No. 542-3032002	ea	X	1	1		
	5820-497-9644		BAG CW-206	ea	X	1	1		
	5995-280-3064		CABLE ASSEMBLY CX-1334/U	ea	X	2	1		
	5995-272-9102		CABLE ASSEMBLY RADIO FREQUENCY CG-1127/U	ea	X	1	1		
	5995-280-3066		CABLE ASSEMBLY, SPECIAL PURPOSE, ELECTRICAL CX-1599/U	ea	X	1	1		
	5995-349-4844		CABLE ASSEMBLY, SPECIAL PURPOSE, ELECTRICAL CX-1852/U	ea	X	2	1		
	5820-571-2558		Ø COVER, ANTENNA: Colvin-Friedman part No. CF-62B	ea	X	1	1		
	5965-784-6670		Ø HEADSET, ELECTRICAL: Navy type 49507A	ea	NX	1	1		
	5970-197-3576		Ø INSULATOR IN-86	ea	X	1	1		
	5805-503-3395		Ø KEY TELEGRAPH KY-116/U	ea	NX	1	1		
	5820-221-5553		MAST BASE MP-65-A B	ea	NX	1	1		
	5820-119-8831		Ø MAST SECTION MS-116	ea	X	3	1		
	5820-199-8843		Ø MAST SECTION MS-117	ea	X	1	1		
	5820-199-8841		Ø MAST SECTION MS-118	ea	X	1	1		
	5965-194-9770		MICROPHONE M-29/U; M-29A/U	ea	NX	1	1		
	5820-396-3196		MOUNTING MT-851/GRC-19	ea	X	1	1		
	5820-503-1250		RECEIVER, RADIO R-392/URR	ea	NX	1	1		

(1) SOURCE MAINTENANCE AND RECOVERABILITY CODE	(2) FEDERAL STOCK NUMBER	(3) DESIGNATION BY MODEL	(4) DESCRIPTION	(5) UNIT OF ISSUE	(6) EXPENDABILITY	(7) QUANTITY AUTHORIZED	(8) (9) ILLUSTRATIONS	
							FIGURE NO.	ITEM NO.
	4020-240-2145		ROPE RP-5: (Authorized quantity will be a minimum of or a multiple of 25 ft)	ft	X	25	1	
	5820-503-3428		TRANSMITTER, RADIO T-195/GRC-19	ea	NX	1	1	
	6145-160-5058		WIRE W-146	ft	X	6	1	
			RUNNING SPARES AND ACCESSORY ITEMS RADIO SET AN/GRC-19					
	5965-784-6670		Ø HEADSET, ELECTRICAL: Navy type 49507A	ea	NX	1	1	
	5970-197-3576		Ø INSULATOR IN-86	ea	X	1	1	
	5805-503-3395		Ø KEY TELEGRAPH KY-116/U	ea	NX	1	1	
	5820-119-8831		Ø MAST SECTION MS-116	ea	X	2	1	
	5820-199-8843		Ø MAST SECTION MS-117	ea	X	1	1	
	5820-199-8841		Ø MAST SECTION MS-118	ea	X	1	1	
	5965-194-9770		MICROPHONE M-29/U; M-29A/U	ea	NX	1	1	



By Order of *Wilber M. Brucker*, Secretary of the Army:

L. L. LEMNITZER,  
*General, United States Army,*  
*Chief of Staff.*

Official:

R. V. LEE,  
*Major General, United States Army,*  
*The Adjutant General.*

Distribution:

*Active Army:*

To be distributed in accordance with DA FORM 12-7 requirements for TM 11 Series (UNCL), plus the following additional formula:

USASA (1)	5-357 (2)
CNGB (1)	5-358 (2)
Def Atomic Spt Agcy (5)	5-359 (2)
Tech Stf, DA (1) Except	5-372 (2)
CSigO (18)	5-376 (2)
USA Abn & Elct Bd (1)	5-377 (2)
USA ATB (1)	5-464 (2)
US ARADCOM (2)	6-37 (2)
US ARADCOM Rgn (2)	6-100 (2)
MDW (1)	6-101 (2)
Seventh US Army (5)	6-125 (2)
EUSA (5)	6-126 (2)
Corps (2)	6-135 (2)
USASCS (25)	6-136 (2)
JBUSMC (2)	6-200 (2)
Units org under fol TOE:	6-201 (2)
1-7 (2)	6-300 (2)
1-17 (2)	6-301 (2)
1-26 (2)	6-315 (2)
1-27 (2)	6-316 (2)
1-37 (2)	6-317 (2)
1-57 (2)	6-319 (2)
1-67 (2)	6-325 (2)
1-107 (2)	6-326 (2)
5-6 (2)	6-327 (2)
5-7 (2)	6-330 (2)
5-8 (2)	6-401 (2)
5-15 (2)	6-501 (2)
5-16 (2)	6-525 (2)
5-17 (2)	6-545 (2)
5-35 (2)	6-575 (2)
5-36 (2)	6-576 (2)
5-37 (2)	6-577 (2)
5-129 (2)	7 (2)
5-138 (2)	7-11 (2)
5-167 (2)	7-12 (2)
5-192 (2)	7-25 (2)
5-215 (2)	7-26 (2)
5-216 (2)	8-15 (2)
5-217 (2)	8-75 (2)
5-218 (2)	8-76 (2)
5-225 (2)	8-77 (2)
5-355 (2)	9-76 (2)
5-356 (2)	9-217 (2)

11-5 (2)	17-85 (2)
11-6 (2)	17-86 (2)
11-7 (2)	17-87 (2)
11-15 (2)	29-56 (2)
11-16 (2)	32-56 (2)
11-37 (2)	32-57 (2)
11-38 (2)	39-51 (2)
11-39 (2)	39-52 (2)
11-55 (2)	39-61 (2)
11-57 (2)	39-71 (2)
11-95 (2)	44-12 (2)
11-98 (2)	44-15 (2)
11-117 (2)	44-16 (2)
11-155 (2)	44-35 (2)
11-165 (2)	44-36 (2)
11-167 (2)	44-37 (2)
11-500 (AA-AE) (2)	44-101 (2)
11-555 (2)	44-115 (2)
11-557 (2)	44-116 (2)
11-587 (2)	44-235 (2)
11-592 (2)	44-236 (2)
11-597 (2)	44-435 (2)
17 (2)	44-436 (2)
17-2 (2)	44-437 (2)
17-22 (2)	44-445 (2)
17-25 (2)	44-447 (2)
17-26 (2)	44-448 (2)
17-35 (2)	44-535 (2)
17-36 (2)	44-536 (2)
17-45 (2)	44-537 (2)
17-46 (2)	44-545 (2)
17-51 (2)	44-547 (2)
17-52 (2)	44-549 (2)
17-55 (2)	55-11 (2)
17-56 (2)	55-12 (2)
17-57 (2)	55-38 (2)
17-62 (2)	55-157 (2)
17-65 (2)	57 (2)
17-66 (2)	57-5 (2)

**NG:** State AG (3); Units—Same as Active Army except allowance is one copy to each unit.

**USAR:** None

For explanation of abbreviations used, see AR 320-50.

## CONDENSED SIMPLEX VOICE OPERATING INSTRUCTIONS FOR RADIO SET AN/GRC-19

- 9, 10, 11, 12. Turn the MEGACYCLES (9) and KILOCYCLES (10) controls until the desired frequency is indicated on the frequency indicator dial or until the desired signal is received. If the CARRIER LEVEL (11) meter indicates when a signal is being received, first adjust the KILOCYCLES control and then adjust the ANT TRIM (12) control to obtain a maximum (peak) indication on the meter. If the CARRIER LEVEL meter does not indicate when a signal is being received, first adjust the KILOCYCLES control and then adjust the ANT TRIM control to obtain maximum loudness at the headset.
13. Adjust the RF GAIN SQUELCH THRESH control clockwise for a loud and clear signal at the headset.
14. Adjust the AF GAIN control for a comfortable signal level at the headset.

## OPERATING PROCEDURE FOR TRANSMITTER, RADIO T-195/GRC-19

15. Set the SERVICE SELECTOR switch to VOICE /FSK.
16. Set the DIAL DIM switch to DIM or FULL.
- 17, 18, 19. Press the switch on the microphone (17) and hold it closed until the transmitter TUNING INDICATOR (18) lights and the test meter (19) indicates in the shaded area marked PA CATHODE.

Note. If the transmitter has been manually tuned from one frequency to another in the same band, the TUNING INDICATOR may not light. In this case, switch the BAND SELECTOR switch to an adjacent band and back again and wait for the tuning cycle to be completed.

20. Hold the microphone about 2 inches from the lips. Press the microphone switch and speak in a normal voice.

## STOPPING PROCEDURE

21. Set the transmitter SERVICE SELECTOR switch to OFF.
22. Set the receiver function switch to OFF.